

INCH-POUND

MIL-PRF-24667C

22 May 2008

SUPERSEDING

MIL-PRF-24667B(SH)

3 June 2005

MIL-PRF-17951E(SH)

W/ AMENDMENT 2

17 September 1992

(see 6.7)

PERFORMANCE SPECIFICATION
COATING SYSTEM, NON-SKID,
FOR ROLL, SPRAY, OR SELF-ADHERING APPLICATION

This specification is approved for use by the Naval Sea Systems Command, Department of the Navy, and is available for use by all Departments and Agencies of the Department of Defense.

1. SCOPE

1.1 Scope. This specification covers non-skid systems, coatings, and coverings for application to weather decks, flight decks, and hangar decks of air capable amphibious aviation and aviation ships. Coatings are applied to steel, aluminum, reinforced plastic, and special hull treatment (SHT) surfaces by spraying, rolling, or other application method as designated by the manufacturer of the non-skid system.

1.2 Classification. The non-skid systems covered by this specification are of the following types and compositions as specified (see 6.2).

1.2.1 Type. The types of non-skids are as follows:

- Type I – High durability, rollable deck coating
- Type II – Standard durability, rollable deck coating
- Type III – Standard durability, rollable resilient deck coating (for use where flexibility is required and where increased weight is not a factor)
- Type IV – Standard durability, sprayable deck coating
- Type V – Extended durability, rollable deck coating
- Type VI – High durability, fast cure, rollable deck coating
- Type VII – Fast cure, temporary repair, rollable deck coating
- Type VIII – Low temperature cure, rollable deck coating
- Type IX – High temperature resistance deck coating
- Type X – Submerged applications
- Type XI – Peel and stick, temporary repair, self adhering deck covering

Comments, suggestions, or questions on this document should be addressed to: Commander, Naval Sea Systems Command, ATTN: SEA 05M2, 1333 Isaac Hull Avenue, SE, Stop 5160, Washington Navy Yard DC 20376-5160 or emailed to CommandStandards@navy.mil, with the subject line "Document Comment". Since contact information can change, you may want to verify the currency of this address information using the ASSIST Online database at <http://assist.daps.dla.mil>.

1.2.2 Composition. The composition of non-skids are as follows:

- Composition G – General use abrasive deck system (all types)
- Composition L – Limited use aircraft carrier landing and run-out area deck system that is not abrasive to the steel arresting cable (composition L applies to Types I, V, VI, VII, VIII, and IX only, and does not apply to Types II, III, IV, and X)
- Composition PS – Self adhering, non-skid deck covering (Type XI only)

1.3 Part or identifying number (PIN). PINs to be used for the coating systems acquired to this specification are created as follows:

M **24667** = **X** **X**

Prefix for Specification Type (see Composition
 Military Number code (see code
 Specification below) below)

Type Code		Composition Code	
Type	Code	Composition	Code
I	A	G	1
II	B	L	2
III	C	PS	3
IV	D		
V	E		
VI	F		
VII	G		
VIII	H		
IX	J		
X	K		
XI	L		

Examples: M24667-A1
 M24667-J2

2. APPLICABLE DOCUMENTS

2.1 General. The documents listed in this section are specified in sections 3, 4, or 5 of this specification. This section does not include documents cited in other sections of this specification or recommended for additional information or as examples. While every effort has been made to ensure the completeness of this list, document users are cautioned that they must meet all specified requirements of documents cited in sections 3, 4, or 5 of this specification, whether or not they are listed.

2.2 Government documents.

2.2.1 Specifications, standards, and handbooks. The following specifications, standards, and handbooks form a part of this document to the extent specified herein. Unless otherwise specified, the issues of these documents are those cited in the solicitation or contract.

FEDERAL STANDARDS

FED-STD-141	-	Paint, Varnish, Lacquer and Related Materials: Methods of Inspection, Sampling and Testing
FED-STD-595/14062	-	Green, Gloss
FED-STD-595/31136	-	Red, Flat or Lusterless
FED-STD-595/33538	-	Yellow, Flat or Lusterless
FED-STD-595/34088	-	Green, Flat or Lusterless
FED-STD-595/36076	-	Gray, Flat or Lusterless
FED-STD-595/36173	-	Gray, Flat or Lusterless
FED-STD-595/36270	-	Gray, Flat or Lusterless
FED-STD-595/37038	-	Miscellaneous, Flat or Lusterless
FED-STD-595/37875	-	Miscellaneous, Flat or Lusterless

DEPARTMENT OF DEFENSE SPECIFICATIONS

MIL-DTL-5624	-	Turbine Fuel, Aviation, Grades JP-4 and JP-5
MIL-D-16791	-	Detergents, General Purpose (Liquid, Nonionic)
MIL-S-22698	-	Steel Plate, Shapes and Bars, Weldable Ordinary Strength and Higher Strength: Structural
MIL-PRF-23236	-	Coating Systems for Ship Structures
MIL-PRF-23699	-	Lubricating Oil, Aircraft Turbine Engine, Synthetic Base, NATO Code Number O-156
MIL-F-24385	-	Fire Extinguishing Agent, Aqueous Film Forming Foam (AFFF) Liquid Concentrate, for Fresh and Seawater
DOD-G-24508	-	Grease, High Performance, Multipurpose (Metric)
MIL-PRF-83282	-	Hydraulic Fluid, Fire Resistant, Synthetic Hydrocarbon Base, Metric, NATO Code Number H-537

DEPARTMENT OF DEFENSE STANDARDS

- MIL-STD-1623 - Fire Performance Requirements and Approved Specifications for Interior Finish Materials and Furnishings (Naval Shipboard Use)

(Copies of these documents are available online at <http://assist.daps.dla.mil/quicksearch/> or <http://assist.daps.dla.mil> or from the Standardization Document Order Desk, 700 Robbins Avenue, Building 4D, Philadelphia, PA 19111-5094.)

2.2.2 Other Government documents, drawings, and publications. The following other Government documents, drawings, and publications form a part of this document to the extent specified herein. Unless otherwise specified, the issues of these documents are those cited in the solicitation or contract.

CALIFORNIA CODE OF REGULATIONS

- Title 22, Division 4.5, Chapter 29, Article 10, §66700 - Waste Extraction Test (WET)

(Copies of this document are available from Barclays West Group, P.O. Box 3066, South San Francisco, CA 94083 or online at <http://ccr.oal.ca.gov/>.)

CODE OF FEDERAL REGULATIONS (CFR)

- 27 CFR21.35 - Formula No. 3-A
- 29 CFR1910 - Occupational Safety and Health Standards
- 40 CFR355 Appendices A and B - The List of Extremely Hazardous Substances and their Threshold Planning Quantities
- 40 CFR372.65 - Chemicals and Chemical Categories to which this Part Applies

(The Code of Federal Regulations (CFR) may be obtained from the Superintendent of Documents, U.S. Government Printing Office, Washington, DC 20401 or online at www.gpoaccess.gov/index.html.)

ENVIRONMENTAL PROTECTION AGENCY (EPA)

- EPA SW-846 - Test Methods for Evaluating Solid Waste, Physical/Chemical Methods
- EPA 600/4-79/020 - Methods for Chemical Analysis of Water and Wastes

(Copies of these document are available from the Environmental Protection Agency, Ariel Rios Building, 1200 Pennsylvania Avenue, N.W., Washington, DC 20460 or www.epa.gov.)

NATIONAL INSTITUTE OF ENVIRONMENTAL HEALTH SCIENCES (NIEHS)

- National Toxicology Program (NTP) latest Annual Report on Carcinogens

(Copies of this document are available from NIEHS, Public Information Office, MD B2-04, Research Triangle Park, NC 27709 or online at <http://library.niehs.nih.gov>)

2.3 Non-Government publications. The following documents form a part of this document to the extent specified herein. Unless otherwise specified, the issues of these documents are those cited in the solicitation or contract.

AMERICAN CONFERENCE OF GOVERNMENTAL INDUSTRIAL HYGIENISTS (ACGIH)

- ACGIH 0100 - Documentation of the Threshold Limit Values and Biological Exposure Indices

(Application for copies should be addressed to the American Conference of Governmental Hygienists, 1330 Kemper Meadow Drive, Cincinnati, OH 45240 or online at www.acgih.org.)

AMERICAN NATIONAL STANDARDS INSTITUTE (ANSI)

- ANSI B74.12 - Size of Abrasive Grain-Grinding Wheels, Polishing and General Industrial Uses

Copies of this document are available from the American National Standards Institute, 25 W. 43rd St, 4th Floor, New York, NY 10036 or online at <http://webstore.ansi.org/>.

ASTM INTERNATIONAL

- ASTM A229/A229M - Standard Specification for Steel Wire, Oil-Tempered for Mechanical Springs (DoD adopted)
- ASTM B117 - Standard Practice for Operating Salt Spray (Fog) Apparatus (DoD adopted)
- ASTM C136 - Standard Test Method for Sieve Analysis of Fine and Coarse Aggregates (DoD adopted)
- ASTM D660 - Standard Test Method for Evaluating Degree of Checking of Exterior Paints (DoD adopted)
- ASTM D661 - Standard Test Method for Evaluating Degree of Cracking of Exterior Paints (DoD adopted)
- ASTM D1141 - Standard Practice for the Preparation of Substitute Ocean Water (DoD adopted)
- ASTM D1652 - Standard Test Methods for Epoxy Content of Epoxy Resins (DoD adopted)
- ASTM D2485 - Standard Test Methods for Evaluating Coatings for High Temperature Service
- ASTM D2572 - Standard Test Method for Isocyanate Groups in Urethane Materials or Prepolymers (DoD adopted)
- ASTM D3272 - Standard Practice for Vacuum Distillation of Solvents From Solvent-Reducible Paints For Analysis (DoD adopted)
- ASTM D3278 - Standard Test Methods for Flash Point of Liquids by Small Scale Closed-Cup Apparatus (DoD adopted)
- ASTM D4541 - Standard Test Method for Pull-Off Strength of Coatings Using Portable Adhesion Testers
- ASTM E260 - Standard Practice for Packed Column Gas Chromatography
- ASTM E1252 - Standard Practice for General Techniques for Obtaining Infrared Spectra for Qualitative Analysis

- | | | |
|-----------|---|---|
| ASTM F137 | - | Standard Test Method for Flexibility of Resilient Flooring Materials with Cylindrical Mandrel Apparatus (DoD adopted) |
| ASTM F718 | - | Standard for Shipbuilders and Marine Paints and Coatings Product/Procedure Data Sheet (DoD adopted) |
| ASTM G8 | - | Standard Test Methods for Cathodic Disbonding of Pipeline Coatings |
| ASTM G14 | - | Standard Test Method for Impact Resistance of Pipeline Coatings (Falling Weight Test) |
| ASTM G154 | - | Standard Practice for Operating Fluorescent Light Apparatus for UV Exposure of Nonmetallic Materials |

(Copies of these documents are available from ASTM International, 100 Barr Harbor Dr., PO Box C700, West Conshohocken, PA 19428-2959 or online at www.astm.org.)

SAE INTERNATIONAL (SAE)

- | | | |
|--------------|---|--|
| SAE AMS1424 | - | Deicing/Anti-Icing Fluid, Aircraft, SAE Type 1 (DoD adopted) |
| SAE AMSC9084 | - | Cloth, Glass, Finished, for Resin Laminates (DoD adopted) |

(Copies of these documents are available from SAE World Headquarters, 400 Commonwealth Drive, Warrendale, PA 15096-0001 or online at www.sae.org.)

SOCIETY FOR PROTECTIVE COATINGS (SSPC)

- | | | |
|------------|---|--|
| SSPC-PA 2 | - | Measurement of Dry Coating Thickness with Magnetic Gages (DoD adopted) |
| SSPC-SP 1 | - | Solvent Cleaning (DoD adopted) |
| SSPC-SP 3 | - | Power Tool Cleaning (DoD adopted) |
| SSPC-SP 10 | - | Near-White Blast Cleaning (DoD adopted) |

(Copies of these documents are available from SSPC Publication Sales, 40 24th Street, 6th floor, Pittsburgh, PA 15222-4656 or online at www.sspc.org.)

2.4 Order of precedence. In the event of a conflict between the text of this document and the references cited herein, the text of this document takes precedence. Nothing in this document, however, supersedes applicable laws and regulations unless a specific exemption has been obtained.

3. REQUIREMENTS

3.1 Qualification. Non-skid systems furnished under this specification shall be products that are authorized by the qualifying activity for listing on the applicable qualified products list before contract award (see 4.2 and 6.3).

3.2 Materials. Each individual component and final combined product of the total non-skid system qualified to this specification shall, when mixed and applied in accordance with the manufacturer's instructions, be in accordance with the appropriate requirements. The composition of the system furnished to this specification shall be the responsibility of the manufacturer, except as limited by this specification.

3.2.1 Description.

3.2.1.1 Types I-X. The total non-skid system shall consist of a non-skid topcoat, anti-corrosive primer (for metal decks only), or primer (for fiberglass decks), any needed intermediate coatings and color topping coatings. The composition of each individual coating of the non-skid system is the manufacturer's responsibility subject only to the limitations of 3.2. Each individual coating of the non-skid system may be provided as one or two parts. Types I, II, III, V, VI, VII, and VIII non-skid coatings and Type III underlayment intermediate coatings shall be formulated for application by roller. Type IV coatings shall be formulated for application by spray only. The application method for Type IX and X coatings shall be at the manufacturer's discretion.

3.2.1.2 Type XI. The non-skid system shall consist of a fabric, film, or composite backing having a uniform closed coat of abrasive particles on the front surface and a pressure sensitive adhesive on the back. The abrasive particles shall be aluminum oxide, silicon carbide, or other abrasive material with a Mohs hardness of 6 or greater. When sized in accordance with the table on allowable limits for the sizing of abrasive grains in ANSI B74.12, the abrasive shall have no more than 2 percent coarser than 54 grit with none coarser than 30 grit. The abrasive shall be bonded to the backing with a resin or similar material. The adhesive on the back surface shall be of the pressure-sensitive type and shall be covered with a removable protective cover. Asbestos fibers and components containing asbestos fibers are prohibited (see 6.3).

3.2.1.2.1 Adhesive and protective cover. The adhesive shall be pressure sensitive, coated to cover the back side of the non-skid system, and shall adhere immediately to smooth, clean, dry deck surfaces without wrinkling, curling, breaking, or lifting. A protective cover shall be used to prevent contamination of the adhesive by foreign matter until the deck treads are applied.

3.2.1.2.2 Sealing compound. The sealer is used to seal the periphery of the tread to prevent ingress of water and other liquids, especially for cotton backed treads. The compound shall be a cold-setting type ready for use and shall have no deleterious effect on the steel or aluminum deck surfaces or on the decking material to which applied. The compound shall be stored in airtight metal containers for a minimum of 18 months without deterioration.

3.2.2 Volatile organic compounds (VOC) limits. When tested as specified in 4.7, the VOC of all individual components of the non-skid system shall not be greater than that specified in table I. The selection of the solvent portions of non-skid system is the responsibility of the manufacturer within the limitations of 3.2.3 and 3.2.5.

TABLE I. VOC limits.

Non-skid type	Maximum VOC (g/L)
Types I, II, III, IV	340
Types V, VI, VII, VIII, IX, and X	250
Type XI sealing compound	481

3.2.3 Hazardous air pollutant (HAP) content. When evaluated as specified in 4.8, the content of HAP solvents in each individual liquid coating of all types shall be not greater than the VOC limit prescribed. Within this limitation and the requirement that the finished coating meet all requirements of this specification, any system solvent selection is the responsibility of the manufacturer.

3.2.4 Hazardous pigments and additives.

3.2.4.1 Metals content. When tested as specified in 4.9, the content of each soluble metal and total content of each metal of the non-skid system shall not be greater than the values listed in tables II and III. In addition, asbestos and asbestos from pigments shall not exceed 5 milligrams per liter (mg/L) for Types I-X. If the total metal content for an individual metal is less than the allowed soluble metal content for that metal, the total metal value may be submitted for the soluble metal value and the actual test for soluble metal need not be performed.

TABLE II. Soluble metals content.

Soluble metal and/or its compound in each individual cured coating	Maximum, mg/L
Antimony	15
Arsenic	5
Barium (excluding barite)	100
Beryllium	0.75
Cadmium	1
Chromium (VI) compounds	1
Chromium and/or chromium (III) compounds	560
Cobalt	50
Copper	25
Fluoride salts	180
Lead	5
Mercury	0.2
Molybdenum	350
Nickel	20
Selenium	1
Silver	5
Tantalum	100
Thallium	7
Tungsten	100
Vanadium	24
Zinc	250

TABLE III. Total metals content.

Metal or its compounds in each individual cured coating	Maximum, %wt
Antimony	0.015
Arsenic	0.005
Barium (excluding barite)	0.1
Beryllium	0.0002
Cadmium	0.0005
Chromium (VI)	0.001
Chromium and/or chromium (III) compounds	0.56
Cobalt	0.005
Copper	0.01
Fluoride salts	0.18
Lead	0.005
Mercury	0.0002
Molybdenum	0.35
Nickel	0.02
Selenium	0.002
Silver	0.001
Tantalum	0.100
Thallium	0.007
Tungsten	0.100
Vanadium	0.01
Zinc	0.25

3.2.4.2 Crystalline silica content. When evaluated in accordance with 4.9, each individual coating of the non-skid coating system shall not contain crystalline silica in excess of 0.1 percent by weight of the dry paint.

3.2.5 Toxicity. The materials used in the coating systems shall have no known carcinogenic or potentially carcinogenic materials identified by OSHA as regulated carcinogens, IARC latest monographs, the latest NTP report, or ACGIH0100; and shall have no extremely hazardous substances (EHS) or toxic chemicals identified in 40 CFR355 and 372, respectively. The manufacturer is responsible for maintaining carcinogenic free materials. The individual coatings shall not contain any of the following materials in excess of 0.06 percent by weight of the wet coating: chlorinated solvents, coal tar, or coal tar derivatives (see 6.2 and 6.5). The manufacturer shall not, unless specific material maximum levels are cited herein, allow the addition of any prohibited materials to the formulation; and when any of these prohibited materials are/may be present, as a result of being present as a trace or impurity in another ingredient(s), the concentration shall not equal or exceed 0.1 percent by weight of any individual coating of the coating system. The coating components and mixed coating shall have no adverse effect on the health of personnel when used for its intended purpose in accordance with the manufacturer's instructions. Questions pertinent to this toxicity requirement shall be referred by contracting activity to the qualifying activity. The qualifying activity will act as advisor to the contracting activity. The qualifying activity will arrange for review of questions by the appropriate departmental medical service.

3.3 Identification characteristics. Values for identification characteristics shall be provided by individual contractors for characteristics as specified in table IV. The values shall be established for each individual coating which comprises the coating system prior to qualification testing. The purpose of these values is to serve as a basis for determining that the material being offered is essentially the same as that which was approved under qualification testing. Conformance inspections shall be as specified (see 4.3).

TABLE IV. Identification characteristics.

Characteristic	Two-part coating		Aggregate	Type XI sealing compound	One-part coating or combined mixture
	Base material, component A	Curing agent, component B			
Chemical nature (percent [%] of each material which comprises 2% or more of the coating)	X	X			X
Percent (%) resin solids by mass	X	X			X
Percent (%) pigment by mass	X	X			X
Percent (%) volatile matter by mass					X
Percent (%) aggregate by mass	X	X			X
Percent (%) solids by mass (not less than 20%)				X	
Percent (%) ash by mass (not more than 4%)				X	
Viscosity (not less than 60 seconds nor more than 160 seconds)				X	
Aggregate size distribution (ASTM C136)			X		
Aggregate composition (% of each material which comprises 10% or more of the aggregate)			X		
Mass (kilograms per liter. [kg/L], pounds per gallon [lbs/gal])	X	X			X
Epoxy content ^{1/} (ASTM D1652)	X				
Active amine hydrogen content		X			
Pigment analysis	X	X			<u>2/</u>
Infrared spectrum of resin	X	X			<u>2/</u>

TABLE IV. Identification characteristics - Continued.

Characteristic	Two-part coating		Aggregate	Type XI sealing compound	One-part coating or combined mixture
	Base material, component A	Curing agent, component B			
Flash point	X	X		X	X
Volatile organic content (VOC) (grams per liter [g/L] coating less water)				X	X
Coverage [ft ² /gal (m ² /L)]					X
NOTES:					
^{1/} Isocyanate content, ASTM D2572, if applicable.					
^{2/} One-part coating only; these analyses are done on the individual components of two-part coatings.					

3.4 Coefficient of friction (COF). The coefficient of static friction of the coating system, when tested in accordance with 4.5.1, shall be determined on topcoats which have been subjected to 50 cycles of wear (conditioning of surface) and on topcoats which have completed the wear test as specified in 4.5.4. The test shall be performed on dry, wet, and oily substrates. When tested in accordance with 4.5.1, the minimum values for each type shall be in accordance with table V.

TABLE V. Coefficient of friction.

	Minimum value		
	Dry	Wet	Oily
<u>Initial</u>			
Types I, V, VI, VII, VIII, and IX	0.95	0.90	0.80
Types II, III, IV, X, and XI	0.90	0.85	0.75
<u>After wear</u>			
Types I, V, VI, VII, VIII, and IX	0.90	0.85	0.75
Types II, III, IV, and X	0.85	0.75	0.65

3.5 Abrasion of cable (composition L only). When tested in accordance with 4.5.2, the composition L non-skid coating system shall produce a maximum average wear of the arresting cable test wire of 0.025 millimeters (1.0 mil; 0.001 inch).

3.6 Impact resistance (types I-X). When tested in accordance with 4.5.3, the minimum impact resistance of each type of non-skid coating shall be in accordance with table VI. Failure of any one of the four conditions tested in 4.5.3 to meet the requirements of table VI constitutes failure of this test.

TABLE VI. Impact resistance.

	Percent, minimum	
	No treatment	15 days immersion
Type I (steel and reinforced plastic substrates)	95	95
Type II, III, and IV (steel and reinforced plastic substrates)	90	90
Types V, VI, VII, VIII, IX, and X (steel substrate only)	95	95

3.7 Resistance to wear (types I-X). When tested in accordance with 4.5.4, the percent weight loss on wear of the coating system shall not exceed 10 percent for Type I, VI, VII, VIII, IX, and X, or 40 percent for Types II, III, and IV, or 2 percent for Type V.

3.8 Protective cover removal (type XI only). When tested in accordance with 4.5.5, the effort required to strip the protective cover away from the adhesive film shall be as shown in table VII.

TABLE VII. Removal of protective cover

Condition	Maximum effort required to pull protective cover away from adhesive film (ounces)
As received	60
After 7 days aging at 150±5 °F	60

3.8.1 Protective cover and adhesive transfer. When tested in accordance with 4.5.5, there shall be no transfer of protective cover material fragments to the adhesive surface or adhesive to protective cover surface when the protective cover is stripped away at a rate of 1 foot per second.

3.9 Adhesion (type XI only).

3.9.1 Shear strength. When tested in accordance with 4.5.6.1, the deck covering shall conform to the requirements of table VIII for a minimum of 1 minute.

TABLE VIII. Shear adhesive strength.

Minimum supported weight (pounds)	
No aging	After 7 days aging
10	10

3.9.2 Strip strength. When tested in accordance with 4.5.6.2, the deck covering shall have the adhesive strength shown in table IX.

TABLE IX. Strip adhesive strength

Drying time	Temperature	Adhesive strength (pounds) minimum
48 hours	80±5 °F	0.75

3.10 Flash point (types I-X). When tested in accordance with 4.5.7, each individual coating of the non-skid system mixed for use shall not flash at temperatures lower than 100 °F (38 °C) except color toppings, which shall not flash at a temperature lower than 80 °F (27 °C).

3.11 Resistance to chemical solutions. When tested in accordance with 4.5.8, the non-skid system shall show no softening, loss of adhesion, separation between coats of the system, discoloration, or other signs of deterioration.

3.12 Resistance to accelerated aging by light and water (types I-X). When tested in accordance with 4.5.9, the non-skid system shall:

- a. Show no loss of adhesion or separation between coats of the system when exposed to ultraviolet light and condensation of water.
- b. The topcoat shall show no cracking more than is indicated by a rating of 6 (ASTM D661).
- c. The topcoat shall show no checking more than is indicated by a rating of 6 (ASTM D660).

3.13 Resistance to accelerated corrosion (types I-X). When tested in accordance with 4.5.10, the non-skid system shall show no loss of adhesion, separation between layers of the system, or corrosion of the steel substrate beyond a 3/8-inch (9-millimeter) radius from the centers of the impact areas or beyond 3/8 inch (9 millimeters) from the edges of the scribe for Type V materials.

3.14 Appearance of the dried coating (types I-X). When tested in accordance with 4.5.11, the primer and intermediate coats, if any, shall dry to a smooth, uniform film, free of spotting, streaking, mud cracking, wrinkling, cratering, or blistering. When non-skid coatings are applied by napless roller, the non-skid topcoat shall have a textured appearance of roughly parallel rows of raised coating, forming peaks or ridges. When the Types I, II, III, V, VI, VII, VIII, XI, and X non-skid coatings are applied by napped roller or trowel, the aggregate shall be uniformly distributed, and shall present a coarse, rough appearance. The non-skid system shall have sufficient sag resistance to retain the raised, textured appearance in the dried coating. When the Type IV and X materials are applied by spray, the topcoat shall present a uniformly coarse, rough appearance over the entire surface. The aggregate shall be distributed uniformly over the surface, and shall protrude prominently above the resin matrix.

3.15 Application properties (types I-X). When tested in accordance with 4.5.12, separate samples of each individual coating of the non-skid system which have been conditioned and mixed at 50, 75, and 90 °F (10, 24, and 32 °C), shall mix easily with no curdling or separation of ingredients, when the Types I, II, III, V, VI, VII, IX, and X non-skid topcoat coatings are applied by roller to metal surfaces at 50, 75, and 120 °F (10, 24, and 49 °C), respectively, there shall be no excess drag or accumulation of coating on the roller, and no excessive spattering of the coating. When Type VIII is applied by roller to metal surfaces at 35 and 50 °F (2 and 10 °C), there shall be no excess drag or accumulation of coating on the roller and no excessive spattering of the coating. When Type IV or X are applied by spray to metal surfaces at 50, 75, and 120 °F (10, 24, and 49 °C), respectively, the material shall flow evenly without running, dripping, spattering or cobwebbing. The appearance of the coating systems shall meet the applicable requirements specified in 3.14.

3.16 Color. The non-skid topcoats and color toppings shall be supplied in one of the following colors from FED-STD-595, as specified (see 6.2): Red to match color 31136; yellow to match color 33538; olive drab to match color 34088; dark gray to match color 36076; haze gray to match color number 36270, ocean gray to match 36173; black to match color 37038; green to match 14062; and white to match color 37875. When tested as specified in 4.5.13, there shall be no discernable color difference between the non-skid or color topping and the color chip. Unless otherwise specified (see 6.2), the color of Type XI shall be black.

3.17 Condition in container (types I-X). When tested in accordance with 4.5.14, liquid one-part coatings, and individual components of two-part coatings, shall not show skinning, livering, curdling, or separation of ingredients, nor hard settling which cannot be dispersed to a uniform consistency by 15 minutes of agitation stirring.

3.18 Coverage (types I-X).

3.18.1 Topcoats. When tested in accordance with 4.5.15, coverage shall be as follows:

- a. Type I, V, VI, VII, and VIII non-skid topcoats shall cover not less than 20 square feet per gallon (ft²/gal) (0.49 square meters per liter (m²/L)) nor more than 30 ft²/gal (0.74 m²/L).

- b. Types II, III, IX, and X (rolled) non-skid topcoat shall cover not less than 25 ft²/gal (0.61 m²/L) or more than 35 ft²/gal (0.86 m²/L).
- c. Types II, III, IX, and X (trowelled) non-skid topcoat shall cover not less than 20 ft²/gal (0.49 m²/L) or more than 22 ft²/gal (0.54 m²/L).
- d. Types IV and IX (sprayed) non-skid topcoat, shall cover no more than 60 ft²/gal (1.5 m²/L).

3.18.2 Primers. When tested in accordance with 4.5.15, primers shall cover an abrasive blasted surface (with surface profile of 75 to 112 micro meters (3.0 to 4.5 mils)) to between 150 and 500 ft²/gal (3.68 and 12.27 m²/L).

3.18.3 Intermediate coats (type III only). When tested in accordance with 4.5.15, intermediate coats shall cover not more than 22 ft²/gal (0.54 m²/L).

3.19 Drying time (types I-X). When tested in accordance with 4.5.16, the maximum drying times for all types, except Types VII and VIII, shall be as follows. Any softening or lifting of coats of a system shall constitute failure:

- a. The maximum drying time of the non-skid topcoat shall be 48 hours at 50 °F (10 °C), 24 hours at 75 °F (24 °C), and 16 hours at 120 °F (49 °C).
- b. The maximum drying time of the primer or intermediate coats shall be 24 hours at 50 °F (10 °C), 18 hours at 75 °F (24 °C), and 16 hours at 120 °F (49 °C).

3.19.1 Type VII. The maximum drying time for the complete application of Type VII systems is 24 hours at 75 °F (24 °C).

3.19.2 Type VIII. The maximum drying time of the primer or intermediate coats shall be 48 hours at 35 °F (2 °C) and 24 hours at 50 °F (10 °C).

3.20 Pot life (types I-X). When tested in accordance with 4.5.17, the minimum pot life values for each coating in the non-skid coating system (except Type III intermediate coats) shall be in accordance with table X.

TABLE X. Pot life.

	Hours, minimum			
	35 °F (2 °C)	50 °F (10 °C)	75 °F (24 °C)	90 °F (32 °C)
Type I	–	3	2	1
Types II, III, IV and X	–	6	4	2
Types V, VI, VII and IX	–	2	0.75	0.375
Type VIII	4	2	–	–

3.20.1 Pot life (type III intermediate coats). When tested in accordance with 4.5.17 the minimum pot life values for Type III intermediate coats shall be 1 hour at 50 °F (10 °C), 40 minutes at 75 °F (24 °C), and 20 minutes at 90 °F (32 °C).

3.21 Fire resistance. When tested in accordance with 4.5.18, the non-skid system shall be in accordance with the requirements of MIL-STD-1623.

3.22 Flexibility (type III and X only). When tested in accordance with 4.5.19, the Type III or Type X coating system shall show no breaking, cracking, or loss of adhesion at the bend. Failure within 0.5 inch (12 millimeters) of the edge of the panel shall be ignored.

3.23 Adhesion of the intermediate coat (type III only). When tested in accordance with 4.5.20, the minimum adhesion strength of the intermediate coat shall be 400 psi.

3.24 Immersion resistance (type X only). When tested in accordance with 4.5.21, the non-skid coating system shall show no pinhole rusting, cracking, or loss of adhesion either between coats or to the substrate. There shall be no blistering rated in excess of ASTM D714, blister size number 4, Few. There shall be no surface imperfections (includes peeling) larger than $\frac{1}{16}$ inch (1.5 millimeters) and any blistering shall be unbroken. Blisters and surface imperfections smaller than $\frac{1}{16}$ inch, which do not increase in size after the fourth month and that do not exceed 3 percent of the test panel surface area, shall not be considered failures. Undercutting at the scribe in excess of $\frac{1}{8}$ inch (3.2 millimeters) shall be considered a failure. Physical damage caused by handling may be ignored in condition evaluation.

3.25 Cathodic protection (CP) compatibility (type X only). When tested as specified in accordance with 4.5.22, the coating system shall not peel, flake, blister, dissolve, or otherwise fail. Undercutting or peeling shall not exceed 4 percent of the area of the test panel and all undercutting and peeling shall be located adjacent to the holiday.

3.26 Pressure cycling (type X only). Pressure cycling shall be performed to determine compatibility of the non-skid applied to Special Hull Treatment (SHT) under simulated in-service conditions. When tested in accordance with 4.5.23, the non-skid applied to the SHT tile shall be visually inspected for cracks and delamination. Any delamination of non-skid from the substrate, cracks in excess of $\frac{1}{16}$ inch in depth or revealing substrate, and cracks greater in length than three inches shall result in failure of the non-skid.

3.27 Strippability (type X only). When tested in accordance with 4.5.24, non-skid shall be removable from Special Hull Treatment (SHT) without significant damage to the substrate or seam filler. The removal rate of the non-skid shall be less than 30 minutes per SHT tile (21 by 22 inches).

3.28 Storage stability (types I-X).

3.28.1 Long-term storage stability. When tested in accordance with 4.5.25.1 the liquid one-part coating, or components of two-part coatings which have been stored for 1 year in their original containers at room temperature (75 °F average room temperature) shall, when mixed in accordance with the directions specified in 3.33, produce a coating system which meets all the requirements of this specification except 3.34.

3.28.2 Accelerated storage stability. When tested in accordance with 4.5.25.2, each individual coating of the non-skid coating system shall meet the requirements of 3.28.1. When tested as specified in 4.5.13, there shall be no discernable color difference between the non-skid and the color chip.

3.29 Weight. When tested in accordance with 4.5.26, the mass of the cured non-skid system, including aggregate, shall not exceed the values in table XI.

TABLE XI. Weight.

	Grams per centimeter squared (g/cm²), maximum	Pounds per square foot (lb/ft²), maximum
Types I, V, VI, VII, VIII, and IX	0.484	0.99
Types II, IV, and X	0.215	0.44
Type III	0.807	1.66
Type XI	0.30	0.62

3.30 Thickness (type XI only). When tested in accordance with 4.5.27, the deck covering shall not exceed 0.080 inches in thickness when applied to the steel deck.

3.31 Size (type XI only). When tested in accordance with 4.5.28, deck covering shall be furnished in treads 6 by 24 inches, 8 by 30 inches or in rolls in 1½, 6, 8, 14, and 24 inches wide and 96 feet long, as specified (see 6.2).

3.32 Temperature resistance (type IX). When tested in accordance with 4.5.29, the coating system shall show no signs of peeling, cracking, blistering, abnormal discoloration, or loss of adhesion.

3.33 Directions for mixing and applying. The manufacturer shall provide written directions for mixing and applying each individual coating used in the non-skid coating system on its container. These directions shall cover both small (1 quart or 1 gallon) (1 liter or 4 liters) and field (5 gallons) (19 liters) kit procedures, and shall specifically state the differences, if any, between the two. These directions shall be in the format specified in ASTM F718 and shall include, as a minimum, information on the mixing ratios by mass and by volume, induction time, pot life, upper and lower temperature and humidity limits for application, coverage per gallon (liters), and safety precautions.

3.34 Performance in-service. When tested in accordance with 4.10, the non-skid system shall show none of the following:

- a. Wear-through (profile of the non-skid surface reduced to showing the primer or steel deck);
- b. ASTM D660 checking (slight breaks in the film not penetrating to the underlying surface) rated less than 8;
- c. ASTM D661 cracking (breaks which extend through the coating film to the substrate surface) rated less than 8;
- d. Breaking (flaking);
- e. Loss of adhesion (peeling);
- f. COF values less than 80 percent of the initial value specified in table V; or
- g. Other deficiency which would adversely affect its performance as specified in table XII.

TABLE XII. Service life values.

	Composition G	Composition L (landings)	Composition PS
Types I, VI, VIII and IX	12 months	10,000	-----
Type II	6 months	5,000	-----
Types III and IV	6 months	-----	-----
Type V	3 years	15,000	-----
Type VII	30 days	1,600	-----
Type X	12 months	-----	-----
Type XI	-----	-----	12 months

3.35 Label.

3.35.1 Type I-X. Manufacturer shall prepare label instructions in accordance with 29 CFR1910. Each container must be affixed with a hazardous chemical warning label in accordance with 29 CFR1910.1200. To comply with the Environmental Protection Agency (EPA) National Emission Standards for Hazardous Air Pollution (NESHAP) requirements for shipbuilding and ship repair, the following two statements must appear on each coating-can label:

- a. Certification that the coating in the container meets the NESHAP requirements for shipbuilding and ship repair.
- b. Statement of the ratio of volatile content to solids expressed as grams of volatile organic hazardous air pollutants (VOHAP) per liter of solids.

3.35.1.1 Composition label. Each container with Composition "G" material, General use non-skid, shall be conspicuously labeled with an upper case "G", blue in color. Each container with Composition "L" materials, limited use in aircraft landing and run-out areas, shall be conspicuously labeled with an upper case "L", green in color.

3.35.2 Type XI. Each container shall be clearly labeled with directions for application and with the following information:

- a. Brand name
- b. Preparation of surface including cleaning agents and primers if required
- c. Method of application
- d. Limit of safe storage and stowage
- e. Safety precautions during application and storage and stowage

4. VERIFICATION

4.1 Classification of inspections. The inspection requirements specified herein are classified as follows:

- a. Qualification inspection (see 4.2).
- b. Conformance inspection (see 4.3).

4.2 Qualification inspection. Tests specified in 4.5.23 (pressure cycling), 4.5.24 (strippability), and 4.10 (performance in-service) shall be performed by the Government. Tests at other than a Government laboratory shall be monitored by the Defense Contract Management Area Operations (DCMAO). Qualification tests shall consist of the tests specified in table XIII. The service test shall be conducted on an in-service Naval vessel as specified in 4.10 after successful completion of all laboratory tests with the exception of 4.5.25.1, which shall be performed concurrently. Testing of products on Government ships shall be conducted at the convenience of the Government.

TABLE XIII. Qualification tests.

Characteristic	Types	Performance paragraph	Test paragraph
Coefficient of friction	All types	3.4	4.5.1
Abrasion of arresting cable	Comp L only	3.5	4.5.2
Impact resistance	I – X	3.6	4.5.3
Resistance to wear	I – X	3.7	4.5.4
Protective cover removal	XI	3.8	4.5.5
Adhesion	XI	3.9	4.5.6
Flash point	I – X	3.10	4.5.7
Resistance to chemical solutions	All types	3.11	4.5.8
Resistance to accelerated aging by light and water	I – X	3.12	4.5.9
Resistance to accelerated corrosion	I – X	3.133	4.5.10
Appearance of the dried coating	I – X	3.14	4.5.11
Application properties	I – X	3.15	4.5.12
Color	I – X	3.16	4.5.13
Condition in container	I – X	3.17	4.5.14
Coverage	I – X	3.18	4.5.15
Drying time	I – X	3.19	4.5.16
Pot life	I – X	3.20	4.5.17
Fire resistance	All types	3.21	4.5.18
Flexibility	III and X	3.22	4.5.19
Adhesion of the intermediate coat	III	3.233	4.5.20
Immersion resistance	X	3.24	4.5.21
Cathodic protection compatibility	X	3.25	4.5.22
Pressure cycling	X	3.26	4.5.23
Strippability	X	3.27	4.5.24
Storage stability	I – X	3.28	4.5.25
Weight	All types	3.29	4.5.26
Thickness	XI	3.30	4.5.27
Size	XI	3.31	4.5.28
Temperature resistance	IX	3.32	4.5.29
Performance in-service	I – X	3.34	4.10
VOC content	I – X	3.2.2	4.7
HAP content	I – X	3.2.3	4.8
Hazardous pigments and additives	I – X	3.2.4	4.9
Metals content	I – X	3.2.4.1	
Crystalline silica content	I – X	3.2.4.2	
Toxicity	I – X	3.2.5	4.6

4.2.1 Systems qualification. Manufacturers shall qualify total non-skid systems consisting of:

- a. Type I, compositions G and L: The total non-skid coating system shall consist of an optional primer (if the non-skid topcoat is designed for direct application to the substrate), any needed intermediate coatings, non-skid topcoat, and color topping coatings.
- b. Type II, compositions G and L: The total non-skid coating system shall consist of a primer, any needed intermediate coatings, non-skid topcoat, and color topping coatings.
- c. Type III, composition G: The total non-skid coating system shall consist of a primer, any needed intermediate coatings, non-skid topcoat, and color topping coatings. (Note: Type III does not include a composition L).
- d. Type IV, composition G: The total non-skid coating system shall consist of a primer, any needed intermediate coatings, non-skid topcoat, and color topping coatings. (Note: Type IV does not include a composition L).
- e. Type V, composition G and L: The total non-skid coating system shall consist of an optional primer (if the non-skid topcoat is designed for direct application to the substrate), any needed intermediate coatings, non-skid topcoat, and color topping coatings.
- f. Type VI, compositions G and L: The total non-skid coating system shall consist of an optional primer (if the non-skid topcoat is designed for direct application to the substrate), any needed intermediate coatings, non-skid topcoat, and color topping coatings.
- g. Type VII, compositions G and L: The total non-skid coating system shall consist of an optional primer (if the non-skid topcoat is designed for direct application to the substrate), any needed intermediate coatings, non-skid topcoat, and color topping coatings.
- h. Type VIII, compositions G and L: The total non-skid coating system shall consist of an optional primer (if the non-skid topcoat is designed for direct application to the substrate), any needed intermediate coatings, non-skid topcoat, and color topping coatings.
- i. Type IX, compositions G and L: The total non-skid coating system shall consist of an optional primer (if the non-skid topcoat is designed for direct application to the substrate), any needed intermediate coatings, non-skid topcoat, and color topping coatings.
- j. Type X, composition G: The total non-skid coating system shall consist of a primer, any needed intermediate coatings, non-skid topcoat, and color topping coatings. (Note: Type X does not include a composition L).
- k. Type XI, peel and stick: The total non-skid system shall consist of a primer (if required), adhesive backed non-skid treads, and sealing compound.

4.2.2 Extension of qualification. Approval of qualification for Navy dark gray to match color 36076 of FED-STD-595 shall constitute approval for other colors of the same type and composition. Systems that are submitted for qualification for Type I that do not pass the durability requirements for Type I but pass the durability requirements for Type II shall be qualified for Type II of the same composition provided that the system passes all other requirements for that type and composition. Approval of qualification for Type III does not constitute approval for Type I and II. A summary of qualification extensions is provided in table XIV.

TABLE XIV. Summary of qualification extensions.

Type/composition for which product is qualified	Type/composition for which qualification is extended																	
	Type I		Type II		Type III	Type IV	Type V		Type VI		Type VII		Type VIII		Type IX		Type X	Type XI
	L	G	L	G	G	G	L	G	L	G	L	G	L	G	L	G	G	PS
Type I/L	X	X	X	X														
Type I/G		X		X														
Type II/L			X	X														
Type II/G				X														
Type III/G					X													
Type IV/G						X												
Type V/L	X	X	X	X			X	X										
Type V/G		X		X				X										
Type VI/L	X	X	X	X					X	X								
Type VI/G		X		X						X								
Type VII/L											X	X						
Type VII/G												X						
Type VIII/L	X	X	X	X									X	X				
Type VIII/G		X		X										X				
Type IX/L															X	X		
Type IX/G																X		
Type X/G																	X	
Type XI/PS																		X

4.3 Conformance inspection. Conformance inspection shall consist of the conformance tests specified in table XV.

TABLE XV. Conformance tests.

Characteristics	Types	Requirement paragraph	Test paragraph
Coefficient of friction ^{1/} and ^{3/}	All types	3.4	4.5.1
Abrasion of arresting cable ^{1/}	Comp L only	3.5	4.5.2
Impact resistance ^{2/}	I – X	3.6	4.5.3
Resistance to wear ^{1/}	I – X	3.7	4.5.4
Protective cover removal ^{3/}	XI	3.8	4.5.5
Adhesion ^{3/}	XI	3.9	4.5.6
Flash point	I – X	3.10	4.5.7
Resistance to chemical solutions (type XI only) ^{3/}	All types	3.11	4.5.8
Appearance of dried coating	I – X	3.14	4.5.11
Application properties	I – X	3.15	4.5.12
Color	I – X	3.16	4.5.13
Size	XI	3.31	4.5.28
Condition in container	I – X	3.17	4.5.14
Coverage	I – X	3.18	4.5.15
Drying time	I – X	3.19	4.5.16
Pot life	I – X	3.20	4.5.17
Flexibility ^{1/}	III and X	3.22	4.5.19
Weight ^{1/} and ^{3/}	All types	3.29	4.5.26
Thickness ^{3/}	XI	3.30	4.5.27

NOTES:

^{1/} Need only to be performed on first lot and every 19,000 L (5000 gal) thereafter.

^{2/} Testing on both conditions (4.5.3 (a) and (b)) shall be performed on the first lot delivered and every 19,000 L (5000 gal) thereafter. For all other lots the seawater immersion testing condition (4.5.3 (a)) can be omitted for conformance testing.

^{3/} Type XI. Testing shall be performed on first lot and every 10,000 square feet of deck covering thereafter.

4.4 Preparation for testing.

4.4.1 Standard conditions. In case of dispute, with the exception of Type VIII, tests shall be performed at standard testing conditions, which are 75±5 °F (24±2 °C) and a relative humidity of 50±5 percent, with the exception of 4.5.12 which shall be performed at the temperatures specified.

4.4.1.1 Type VIII. Low temperature curing materials shall be applied and cured at 35 °F (2 °C). Testing shall be conducted at standard conditions unless otherwise specified herein.

4.4.2 Panel substrate material. Steel panels in accordance with 4.4.2.1 shall be used for all of the tests specified in 4.5 which require test panels, except Type XI (unless otherwise noted within the particular test requirement). Reinforced plastic in accordance with 4.4.2.2 shall be used for the tests specified in 4.5.3 and 4.5.8. Polished clean stainless steel shall be used for tests specified in 4.5.6.1. Buffed high tensile steel and galvanized steel panels shall be used for tests specified in 4.5.6.2.

4.4.2.1 Steel surfaces. Ordinary strength steel panels, in accordance with Grade A of MIL-S-22698, 1/8 inch (3 millimeters) thick (nominal), except for the impact resistance test (see 4.5.3) and temperature resistance test (see 4.5.29) where panels shall be 1/4 inch (6 millimeters) thick, shall be abrasive-blasted to a uniform near white-metal finish in accordance with SSPC-SP 10 to a 3- to 4.5-mil (75- to 115-micrometer) angular profile, unless otherwise specified herein. The panels shall then be cleaned with oil-free air or vacuum, and protected from moisture during storage. The qualification test report shall indicate degree of surface preparation and the profile achieved.

4.4.2.1.1 Compromised steel surfaces. For Type VII materials, the steel panels for use in the tests in sections 4.5.3 and 4.5.8 shall not be abrasive blasted, but shall be prepared to a power tool cleaned surface in accordance with SSPC-SP 3 with a 3.0 to 4.5 mil profile followed by SSPC-SP 1.

4.4.2.2 Reinforced plastic surface. Fiberglass surface coating shall be applied to an "A" face of AC plywood, and shall consist of two layers of chopped strand mat, 1.5 oz/sq-ft, Owens-Corning M-721 or equivalent and one surface layer of 10.5 oz/sq-yd woven cloth, style 7500, with amine-silane treatment. Fiberglass reinforcement shall be applied in three sequential layers each well saturated and rolled or squeezed free of air bubbles, with a resin system of Reichhold Chemicals 37-127 epoxy and 37-607 hardener at a ratio of 100 to 45 parts by weight respectively, or equivalent. Final resin coat shall cover the glass fiber by 10-20 mils. The glass fiber shall meet the requirements of SAE AMSC9084, Type XII or Type XIIA, Class 2. The covering shall be allowed to cure seven days minimum. The surface shall be sanded smooth with 120 grit aluminum oxide.

4.4.2.3 Special hull treatment (SHT). SHT test panels shall be prepared using ordinary steel plate in accordance with 4.4.2.1, 24 inches square by 3/8 inches thick (600 millimeters square by 9 millimeters thick) shall be coated with DTNSRDC 2844-1109 or 1110 epoxy paint, and the SHT adhered using DTNSRDC 2844-1102. The SHT shall be applied so that there are a minimum of two seams present. The seams shall be filled with a system compatible seam filler.

4.4.3 Preparation of test panels. Panels prepared as specified in 4.4.2 shall be primed with the primer, if any, designated by the manufacturer (see 3.2 and 3.2.1). The primer film thickness on test panels shall be measured in accordance with SSPC-PA 2 and shall be within a tolerance of 1 mil (± 0.025 millimeters) of the manufacturer's recommended thickness. The primer thickness shall be listed in the qualification report. If a range is given for the primer thickness, the minimum number shall be used for testing purposes except for those tests in section 4.5.3 and 4.5.8 where the maximum number shall be used. The primer shall be allowed to dry for the time specified by the manufacturer (see 3.33). The intermediate coats, if any, and topcoat shall be mixed, kept at standard conditions during the induction time, if any, applied, as specified in the manufacturer's instructions (see 3.33), and allowed to cure for 14 days at standard conditions unless otherwise specified in the test method. Testing of Type VI materials shall begin immediately following 3 days of cure. Testing of Type VII materials shall begin immediately following 24 hours of cure. Unless otherwise stated by the manufacturer's ASTM F718, Type VIII materials shall be applied and cured at 35 °F (2 °C).

4.4.3.1 Type XI. The surface of the test panels to which the deck covering is attached shall be free from all rust, scale, and organic matter. The non-skid system shall be applied to the test panels, including sealing compound, and allowed to cure for 48 hours at room temperature before conducting tests.

4.5 Tests. Tests shall be conducted in accordance with the procedures specified herein. Each result shall be compared with the applicable requirement in section 3, and evaluated for qualification (see table XIII).

4.5.1 Coefficient of friction. The COF shall be determined as follows and shall be in accordance with the requirements of 3.4.

4.5.1.1 Test panel preparation. Six 6- by 12- by ¼-in (nominal) (150- by 300- by 6-millimeter) steel panels, prepared in accordance with 4.4.3 shall be coated with non-skid in accordance with the manufacturer's ASTM F718 data sheet. Roll-on non-skid coating materials shall be applied such that the ridges run parallel to the 12 inches (300 millimeters) dimension. Three of the test panels shall be subjected to 50 cycles of wear, which are designated as "unworn", and three shall be subjected to 500 cycles of wear, designated as "worn", in the cable abrasion tester in accordance with the requirements of 4.5.2.1.

4.5.1.2 Test apparatus. The COF testing device shall be constructed of the following components:

- a. The drag sled shall be constructed of a steel block having dimensions of 5.75 inches (145 millimeters) by 4 inches (100 millimeters) by 0.85 inch (22 millimeters) with one 100-millimeter edge having a 0.75-inch (19-millimeter) radius. The 100 millimeters by 22 millimeters face with the radius edge will also receive a screw eye in the center of the face. The block will be covered with a vulcanized neoprene rubber pad covering the two faces joined by the radius edge and the radius edge itself. The rubber pad shall have a Type "A" Durometer hardness of 57 ± 2 and a nominal thickness of ⅛ inch (3 millimeters). The total weight of the drag sled including the rubber pad and screw eye shall be 6.0 ± 0.5 pounds (2.7 ± 0.2 kilograms).
- b. A force gage shall be used which can measure at least 10 pounds (4.5 kilograms) with a minimum resolution of 0.02 pound (0.01 kilogram). The gage shall also be able to output information to a PC for analysis. Chatillon force gage model DFS-0050 (Standard model) has been found acceptable for this application.
- c. A computer program which can collect and save data from the force gage as well as analyze the data to determine the COF at the moment at which motion begins (static friction).
- d. A platform which moves across a 1-inch (25-millimeter) minimum distance at a constant speed of 12 inches (300 millimeters) per minute (nominal).
- e. The COF tester and the panels shall be securely fastened to a stable platform to ensure no extraneous slippage of the panels or the tester occurs, and that there will be no interference with the securing attachment and the motion of the sled.

4.5.1.3 Test procedure. The test shall be conducted on the six panels as prepared above. Each panel shall be subjected to this test procedure under the following three conditions:

- a. COF test shall first be run with the panel dry.
- b. After completion of the dry condition test, the panels shall be wetted with synthetic seawater in accordance with ASTM D1141, and the tests shall be repeated.
- c. After completion of the wet condition test, the panels shall be rinsed in tap water to remove the synthetic seawater, dried at 248 °F (120 °C) for 1 hour, and cooled to standard conditions. The panel shall then be wetted with aircraft turboshaft engine oil in accordance with MIL-PRF-23699, and the test shall be repeated.

The sled shall be placed rubber side down on the panel and connected to the force gage in such a way that no tension is experienced while minimizing slack between the force gage and the sled. A rigid rod is most useful in accomplishing this. The sled shall be moved across the panel at a rate of approximately 12 inches (300 millimeters) per minute. The sled should move for approximately 5 seconds to give a travel distance of 1 inch (25 millimeters). The computer program will determine COF data by dividing the force required to initiate movement of the sled by the weight of the sled and record the results. Five replicate measurements shall be made; the panel shall then be turned 90 degrees and five additional measurements shall be made. The average of the ten readings for each panel condition, unworn and worn, (30 total) shall be computed. The COF shall meet the requirements of 3.4.

4.5.1.4 Sled calibration. Since friction readings are a function of the surface condition of the steel sled rubber surface, a steel sled with a new vulcanized neoprene rubber pad shall be used for each product tested. In addition, sleds used for the different test conditions shall be used only for the same conditions. That is a sled used dry shall only be used to test dry friction specimens, sleds used with water shall be used only with water friction specimens, and sleds used to measure oily friction shall be used only for tests of friction on oily specimens. Sleds shall be calibrated against a flat steel block having machined cross hatched v- shaped grooves having a nominal depth of 0.05 inch (1.27 millimeters) and a nominal groove peak to peak distance 0.01 inch (0.25 millimeter). Sleds may continue to be used in testing the same product until repeat measurements on the calibration surface changes by more than five percent (plus or minus). All calibrations shall be performed on the same calibration block since the intent of the calibration blocks are only to determine reproducibility of readings by the rubber pad and thus rubber pad replacement criteria. Calibration of sleds on different calibration blocks during the determination of friction values on a test specimen is not permitted. Calibration shall be performed before and after test specimen friction determinations and the values obtained recorded and reported with the test value.

4.5.2 Abrasion of arresting cable (composition L only). Three 12- by 6- by ¼-inch (300- by 150- by 6- millimeter) (nominal) test panels shall be prepared as specified in 4.4.3. Each panel shall be conditioned by running 50 cycles in the cable abrasion tester specified herein before determination of the abrasion of the arresting cable. Each panel shall then be abraded by a new ⅜-inch (3-millimeter) (nominal) diameter cold-rolled ASTM A229 Class 2 steel rod of sufficient length to completely span the width of the sample plate. Before use, the diameter of each rod shall be measured to the nearest 0.1 mil (0.0025 millimeter) in a minimum of ten places that will come in contact with the test panel. After completion of 200 cycles in the abrasion machine, the rod shall be removed from the jig and the diameter of the rod shall be measured to the nearest 0.1 mil (0.0025 millimeter) in the same places as measured before the rod was abraded. The mean difference in thickness of the rod shall be computed and that number shall be recorded as the wear value for that rod. The average of the wear of the three rods shall be computed, and this value shall be used to determine conformance to the requirements specified in 3.5. The device used for the measurement of the rods shall have a minimum precision of 0.1 mil (0.0025 millimeter) and shall be capable of measuring an irregular surface. One device that has the necessary measurement capability that may be used for the measurement of the rods is a Nikon Instruments Inc. V-12B profile projector, or equivalent.

4.5.2.1 Cable abrasion test apparatus. The test apparatus shall be constructed so that there will be relative motion between the steel rod and the test panel, and shall have the following features:

- a. A carriage or jig on which either the test panel or the steel rod is mounted. The test panel and the rod shall be securely fastened to preclude movement within the carriage or jig during the test, and shall be moved in a reciprocating motion 9 inches (225 millimeters) along the long axis of the sample panel.
- b. The steel rod shall be in contact with the test panel, with the axis of the rod horizontal and at a right angle to the direction of the reciprocating motion. The clamps holding the rod shall not come into contact with the test panel, and shall not permit the rod to bend, twist, or rotate during the test. The test apparatus shall be constructed so as the contact force between the rod and the sample is $30 \pm \frac{1}{4}$ pounds (13.6 \pm 0.1 kilograms) during the test.

4.5.3 Impact resistance (types I-X). Four 6- by 6- by ¼-inch (150- by 150- by 6-millimeter) (nominal) test steel, and reinforced plastic panels as specified in 4.4.2 shall be prepared as specified in 4.4.3 (prepared using the highest primer thickness specified). Immediately before testing, two panels shall be subjected to each of the following treatments: (a) no treatment and (b) 15 days of immersion at room temperature in either natural seawater, or synthetic seawater in accordance with ASTM D1141. Panels that are immersed shall have an epoxy anticorrosive coating applied to the edges and back side of the panels.

4.5.3.1 Impact test apparatus. The impact test shall be conducted with a device similar to that depicted in ASTM G14, except that the v-block securing device shall be replaced with a steel base that is at least 1.5 inches (40 millimeters) thick, is capable of securing the sample plate without allowing movement when impacted and allows alignment of the plate with the designated impact locations. A machinist's magnetic vice has been demonstrated to have this capability. The *tup* nose shall have a ⅝-inch (15.875-millimeter) hemispherical head and the weight of the *tup* shall be modified so that it is 4.0 pounds (1.8 kilograms).

4.5.3.2 Impacting the sample. Immediately upon removal from treatment, each panel shall be subjected to 25 impacts by the *tup* dropped from a distance of 4.0 feet (1.2 meters). Type IV coatings shall be subject to 3.0 feet (910 millimeters). The impacts on the panel shall be made in the sequence specified on figure 1. Successive points of impact shall form a 5 by 5 pattern, enclosed within an area of about 9 square inches (58 square centimeters), in which the impacts are equally spaced $\frac{3}{4} \pm \frac{1}{16}$ inch (20±1.5 millimeters) center-to-center from their nearest neighbors.

2	15	11	7	3
6	19	23	20	16
10	22	25	24	12
14	18	21	17	8
1	5	9	13	4

FIGURE 1. Impact sequence for the impact resistance test.

4.5.3.3 Removal of loosened non-skid coating. Upon completion of each impact test, the panel shall be probed by hand with a hand held, sharpened, 1 inch (25.4 millimeters) (nominal) steel cold chisel in an area that received no impacts in order to judge the force needed to remove the coating. The panel shall then be probed in the impact area with the chisel, using a force less than that used in the non-impact area, and coating which has been loosened by the impact of the steel ball shall be removed from the panel.

4.5.3.4 Evaluation. The percentage of coating system remaining intact and tightly adhering to the panel shall be evaluated as follows: In the 5 by 5 pattern of impacts, there are 40 pairs of impacts separated by $\frac{3}{4}$ inch (20 millimeters) center to center. In every case in which one or more layers of the coating system has been removed with the chisel, so as to connect one pair of impacts, the percentage of intact coating system is reduced by 2.5. Thus, a passing value of 90 percent indicates that no more than four pairs of adjacent impacts are connected. Results for duplicate panels tested under the same conditions shall be averaged. Failure of one of the two conditions constitutes failure of this test. Impact resistance for each type shall be in accordance with the requirements of 3.6.

4.5.4 Resistance to wear (types I-X). Three steel panels 12 by 6 by $\frac{1}{8}$ inches s (300 by 150 by 3 millimeter) (nominal) shall be prepared as specified in 4.4.3. The mass of each panel shall be measured to the nearest 0.001 pound (0.5 gram) before application of the coating system. Each panel shall be abraded by the cable abrasion tester specified in 4.5.2 for 50 cycles and then its mass determined. The panel shall then be worn for an additional 450 cycles in the cable abrasion tester for all Type coatings and an additional 300 cycles for Type V coatings. For abrasive coatings, the wire in the cable abrasion tester shall be replaced after the first 50 cycles and every 150 cycles thereafter. After completion of the wear, the final coating mass shall be taken. The percent of determined mass loss is calculated as follows:

$$\text{Percent mass loss} = 100 \times (M2 - M3) / (M2 - M1)$$

- M1 – Mass of panel before coating
- M2 – Mass at 50 cycles
- M3 – Mass at end of test

The average percent of determined mass loss of the three panels shall be computed. Loss of mass shall conform to the requirements of 3.7.

4.5.5 Protective covering removal (type XI only). Twenty specimens of deck covering, 1 by 7 inches (25 by 178 millimeters), shall be prepared for testing. Ten specimens shall be tested immediately in accordance with 4.5.5.1. Ten specimens shall be placed in an oven at 150±5 °F (68±5 °C) for 7 days cooled for 2 hours, and then tested in accordance with 4.5.5.1. The amount of effort required to pull protective cover away from adhesive film shall be determined for each set of ten specimens, the results averaged, and the average of the ten results shall not exceed the maximum values specified in 3.8.

4.5.5.1 Apparatus and procedure. The apparatus shall be a pendulum type tensile testing machine. The test shall be made with the stressing jaw moving at a speed of 12 inches/minute (30 centimeters/minute). The protective cover of the 1 by 7 inches (25 by 178 millimeters) specimen of deck covering shall be partially removed from one end so that the free protective cover end may be placed in the stressing jaw and the deck covering end placed in the fixed jaw. The maximum tension required to remove the remainder of the protective cover shall be taken as the amount of removal effort required for each specimen. The pawls of the pendulum arm shall be taped back in an open position. The scale shall be graduated to record results in ounces.

4.5.5.2 Protective cover and adhesive transfer. The protective cover of a 6- by 24-inch (152- by 610-millimeter) tread shall be pulled away from the deck covering at a speed of 30 1 foot/second (centimeter/second). The protective cover and the decking material shall then be examined for signs of transfer of the adhesive to the protective cover surface and for retention of protective cover fragments by the adhesive surface (3.8.1).

4.5.6 Adhesion (type XI only).

4.5.6.1 Shear strength. Fifteen specimens, 1 by 7 inches (25 by 178 millimeters), shall be prepared from each lot of deck covering. Five specimens shall be tested immediately in accordance with 4.5.6.1.1. Ten specimens conditioned in an oven at 150 ± 5 °F (68 ± 5 °C) for 7 days, and tested in accordance with 4.5.6.1.1. The results shall be as specified in 3.9.1.

4.5.6.1.1 Procedure. The protective cover shall be stripped back approximately 2 inches (51 millimeters) from one end of each 1 by 7 inches (25 by 178 millimeters) specimen as it is to be tested, care being taken to avoid any foreign matter coming in contact with the exposed adhesive film. With the use of a template such as shown in figure 3, the exposed end shall be adhered to a polished clean stainless steel plate so that exactly 1 square inch of the specimen has contact. The plate shall then be inserted in a jig, and pressure applied by any hydraulic or mechanical press to provide 65 lb/in^2 (5 kg/cm^2) of pressure in mounting test specimens. The specimen shall remain under this pressure for 1 minute. The ten specimens aged in oven at 150 ± 5 °F (68 ± 5 °C) for 7 days and the five specimens without aging shall be mounted in the above manner, and allowed to set at room temperature for 48 hours, after which time five each of the aged and unaged specimens shall be tested for adhesion at room temperature (80 ± 5 °F (27 ± 5 °C)). The tests shall be made by fixing the steel plate in a vertical position leaving 6 inches (152 millimeters) of the specimen strip below to which a weight can be attached and suspended as shown on figure 4. Weight of the amount specified in table VIII shall be placed in the weight pan. The deck covering shall be considered to have passed this test if at least three of the group of five specimens have supported the weights for a period of 1 minute.

4.5.6.2 Strip strength. Eight samples of high tensile steel plates and eight samples of galvanized steel plates, each 10 by 16 in by $\frac{1}{8}$ inches (254 by 305 by 3 millimeters) (nominal) thick, shall be prepared by buffing the surface on one side with a power-driven, flexible-backed number 24 abrasive disk using such pressure as will just polish the surface of the metal. The buffed plates shall then be cleaned with a solvent. The deck covering, with protective cover removed, shall be applied to the clean steel plates by rolling five times in each direction with a roller traveling at approximately $7\frac{1}{2}$ feet/minute (229 centimeters/second). The roller shall be as shown on figure 5 and shall be composed of steel disks 7 inches (178 millimeters) in diameter and approximately $\frac{1}{4}$ inch (6 millimeters) in thickness. The disks shall have a central hole 2 inches (51 millimeters) in diameter and shall be assembled on a $\frac{1}{2}$ -inch (13-millimeter) diameter rod, with a disk having a $\frac{5}{8}$ -inch (16-millimeter) hole fastened on each end. When the roller is pulled along by the handle, the disks shall be free to align themselves vertically so that they conform to local irregularities of the specimen surface in $\frac{1}{4}$ -inch (6-millimeter) steps. The 7-inch (178-millimeter) diameter roller shall result in a loading of 10 lb/in^2 (1 kg/cm^2) of width which approximates 65 lb/in^2 (5 kg/cm^2). The results shall be as specified in 3.9.2.

4.5.6.2.1 Adhesion at room temperature (80 ± 5 °F (27 ± 5 °C)). Three specimens attached to tensile steel and three specimens attached to a galvanized steel plate prepared as specified in 4.5.6.2 shall be employed. The specimens shall be allowed to dry for a total of 48 hours and then immediately tested. The method of testing strip adhesion to metal shall be as shown on figure 6. Adhesive strength shall be taken as the highest load at which the separation in 1 minute does not exceed 1 inch (25 millimeters). The average of the two highest values obtained on the three strips shall then be considered as the adhesive strength between the deck covering and the metal.

4.5.7 Flash point (types I-X). The flash point shall be determined in accordance with ASTM D3278 on each individual coating of the non-skid coating system after each has been thoroughly mixed for use. Flash point of each coating making up the non-skid system shall be in accordance with the requirements of 3.10.

4.5.8 Resistance to chemical solutions.

4.5.8.1 Types I–IX. Sixteen 6- by 2- by 1/8-inch (150- by 50- by 3-millimeter) (nominal) steel, and reinforced plastic panels (for Types II, III, and IV only) as specified in 4.4.2 shall be prepared as specified in 4.4.3 (prepared using the highest primer thickness specified). Eight panels shall be subjected to two impacts from the impact test apparatus (see 4.5.3); the impacts shall be 4 ± 0.25 inches (100 \pm 6.4 millimeters) apart and equidistant from the edges and sides of the panels. Each of eight wide mouth jars with tightly-fitting caps shall be filled to a depth of 3 inches (75 millimeters) (nominal) with one of the following materials:

- a. Grease in accordance with DOD-G-24508.
- b. JP-5 jet fuel in accordance with MIL-DTL-5624.
- c. Hydraulic fluid in accordance with MIL-PRF-83282.
- d. Ethyl alcohol in accordance with 27 CFR21.35.
- e. Aircraft engine turboshaft lubricating oil in accordance with MIL-PRF-23699.
- f. Detergent in accordance with MIL-D-16791, 0.5 percent solution in synthetic seawater in accordance with ASTM D1141.
- g. Aqueous fire fighting foam in accordance with MIL-F-24385, 10 percent solution in synthetic seawater in accordance with ASTM D1141.
- h. Deicing-defrosting fluids in accordance with SAE AMS1424.

Two panels, one impacted and one unimpacted for each primer thickness, shall be placed in each jar, each panel resting on its 2-inch (50-millimeter) side, with one-half immersed and one-half above the test material and in such a manner as to not touch each other. The jars shall be sealed tightly and kept at standard conditions for 4 weeks for all fluids except JP-5, ethyl alcohol, and deicing-defrosting fluid, which shall be tested for 24 hours only. Upon removal from the immersion medium, the panels shall be probed with a sharp, 1-inch (25-millimeter) wide blade, wood chisel and compared with the identical untested control panel to detect signs of softening, loss of adhesion, or separation between layers of coating, and otherwise examined for conformance to 3.11. The panels immersed in JP-5, ethyl alcohol, and deicing-defrosting fluid shall be allowed a 6-hour recovery period before evaluation. All other panels shall be examined for conformance immediately after removal from the immersion medium. Results of the evaluation shall be in accordance with the requirements of 3.11.

4.5.8.2 Type X. Eight steel panels shall be prepared as described in 4.5.8.1 with four panels receiving impacts. The panels will be immersed in solutions (a), (c), (f), and (g), and be tested and evaluated as above. Results of the evaluation shall be in accordance with the requirements of 3.11.

4.5.8.3 Type XI. Specimens of deck covering 6 by 2 inches (15 by 5 millimeters) (nominal) shall be immersed for one hour in solution (f) of 4.5.8.1 with the addition of lampblack until the solution is dark gray. After immersion, the specimen shall be rinsed for 1 minute with tap water at 140 °F and dried with an air jet. The specimen shall then be examined for softening, stains, streaking, or loss of color as required by 3.11.

4.5.9 Resistance to accelerated aging by light and water (types I-X). Three 4- by 6- by 1/8-inch (100- by 150- by 3-millimeter) (nominal) steel test panels shall be prepared as specified in 4.4.3. Two of the panels shall be subjected to two impacts from the impact tester (see 4.5.3); each impact shall be 1 inch (25 millimeters) from the edge (3 inch dimension) and 1.5 inches (40 millimeters) from the sides of the panel (6 inch dimension). Except for Type V, the panels shall be tested as specified in ASTM G154, Cycle 2, for 200 hours in an accelerated weathering tester (Q-U-V Cabinet, The Q Panel Corporation, Cleveland, OH; Atlas UVCON, The Atlas Electric Devices Company, Chicago, IL; or equal) which operates on alternate 4-hour periods of condensation at 104 °F (40 °C). The lamps shall be UV-B lamps number QFS-40 or equal. At the completion of the exposure period, the panels shall be visually evaluated for compliance with 3.12.

4.5.10 Resistance to accelerated corrosion (types I-X). Two 4- by 6- by 1/8-inch (100- by 150- by 3-millimeter) (nominal) steel test panels shall be prepared as specified in 4.4.3, except that both sides and edges of these panels shall be primed. One panel shall receive two impacts from the impact tester as specified in 4.5.3. The impacts shall be 1 inch (25 millimeters) (nominal) from the end and 1.5 inches (40 millimeters) (nominal) from the sides of the panel. Both panels shall be tested for 1000 hours in a salt fog cabinet as specified in ASTM B117. The coating systems shall be examined for loss of adhesion and separation between coats. A portion of the coating shall be removed from each steel panel, and the underlying steel shall be observed for corrosion under the coating system. Loss of adhesion and allowed corrosion shall be in accordance with the requirements of 3.13.

4.5.10.1 Sequential testing for Type V materials. Two panels 6 by 12 by 1/4 inches (150 by 300 by 6 millimeters) shall be prepared as specified in 4.4.3 and scribed with a 5.75-inch long scribe down to the substrate and centered vertically on the panels (see figure 7). The panels shall be tested in accordance with 4.5.9 for 400 hours followed by testing the same panels in accordance with 4.5.10 for 2000 hours. If the panels comply with 3.12 and 3.13, they shall be sequentially tested in accordance with 4.5.4 and 4.5.3 and examined for compliance with 3.7 and 3.6. For testing to 4.5.3.2, impacts shall be limited to 20 per panel with no impact in the scribed area (see figure 2). Impact in the scribed area shall be disregarded.

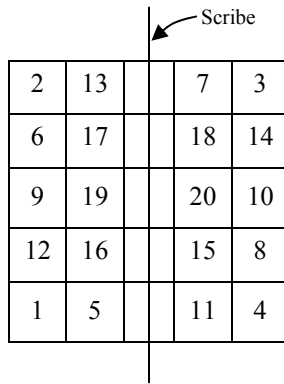

FIGURE 2. Impact sequence for type V impact resistance test.

4.5.11 Appearance of the dried coating (types I-X). Separate samples of each coating component of the system shall be conditioned and then mixed at 75 °F (24 °C). Mixing shall be in accordance with the manufacturer’s ASTM F718 data sheet. After the manufacturer designated induction time for the temperature, the coating shall be applied in accordance with the ASTM F718 instruction to a test plate. After curing, the appearance shall be in accordance with the requirements of 3.14. The appearance of the primer and each intermediate coat shall be observed before application of the subsequent coat.

4.5.12 Application properties (types I-X). One 12 by 6 by 1/8 inches (250 by 150 by 3 millimeters) (nominal) primed steel panels shall be equilibrated at the temperature at which the application properties are to be determined. Except for Type VIII, separate samples of each individual coating of the non-skid coating system shall be conditioned, mixed and inducted for one-half of the specified pot life period for that temperature in accordance with the manufacturer's ASTM F718 data sheet at 50, 75, and 90 °F (10, 24, and 32 °C), respectively. Coatings shall be applied to the panels at the matching temperatures in accordance with the manufacturer's ASTM F718 instructions to metal surfaces at 50, 75, and 120 °F (10, 24, and 49 °C), respectively. Separate samples of Type VIII materials shall be stored for 24 hours at 68 °F (20 °C). Type VIII materials shall be applied and cured at 36 °F (2 °C). Spraying, or rolling properties shall be in accordance with 3.15, as appropriate. For this test, material from the pot life test specified in 4.5.17 shall not be used. Type I, II, III, V, VII, VIII, or IX and X (where required by the manufacturer's ASTM F718 data sheet) coating shall be spread over the panel with a roller, and then rolled in one direction to produce the characteristic rolled appearance (see 3.14). Type IV or IX and X (where required by the manufacturer's ASTM F718 data sheet) material shall be sprayed in several passes to produce a uniform finish (see 3.14). Type IX material shall be applied by the method specified in the manufacturer's ASTM F718 data sheet. During mixing and application, the coating shall be observed and evaluated for conformance with 3.15. These panels may be used for the drying time test in 4.5.16.

4.5.13 Color (types I-X). Compare a sample plate prepared in accordance with 4.4.3 to the appropriate FED-STD-595 color chip. The results shall be in accordance with the requirements of 3.16. Color toppings shall be mixed in accordance with the manufacturer's ASTM F718 data sheet. Draw down the color topping on separate glass panels using a sufficient number of successive crosscoats (each having a wet film thickness (WFT) of 0.003" or 3 mils) so that additional coats produce no noticeable change in color. Dry at ambient laboratory conditions for 24 hours after each coat. Compare the sample to the appropriate FED-STD-595 color chip. The results shall be in compliance with 3.16.

4.5.14 Condition in container (types I-X). The liquid one-part coating, or components of two-part coatings, shall be examined in accordance with method 3011.1 of FED-STD-141 for the defects specified in 3.17. The presence of ingredients which cannot be redispersed within 5 minutes by hand stirring with a paddle for a 1-gallon (4-liter) or smaller quantities or stirring (agitation) with a power mixer or mechanical shaker for 5-gallon (19-liter) quantities shall constitute a failure of this requirement. Condition in container shall be in accordance with the requirements of 3.17.

4.5.15 Coverage (types I-X). One 36- by 36- by 1/8-inch (914- by 914- by 3-millimeter) steel panel shall be prepared as specified in 4.4.3. Coverage shall meet the requirements in 3.18.1, 3.18.2, and 3.18.3. For Type III coatings, the primer, intermediate coats, and topcoat shall be separately applied with curing times observed in accordance with the directions provided in 3.33. Before applying subsequent coats of the system, each individual coat of the system shall be weight-determined using the formula below.

$$\text{Coverage} = (\text{Area} \times \text{Mass/Unit Volume}) / (\text{Mass 2} - \text{Mass 1})$$

Where:

Area	=	914 by 914 (36 by 36)
Mass/unit volume	=	weight per kilogram/liter [kg/L] or pounds per gallon [lbs/gal] material (not including container weight, see table III)
Mass 1	=	weight of panel before application
Mass 2	=	weight of panel after application

4.5.16 Drying time (types I-X). Three 6- by 6- by 1/8-inch (150- by 150- by 3-millimeter) (nominal) panels shall be prepared in accordance with 4.5.12 each at one of the temperatures specified in 3.19 and maintained at that temperature. The drying time of the primer and intermediate coats shall be determined by applying the subsequent coat at the minimum allowable drying time for that temperature. The finished panels shall be kept at the specified temperature for the allowable drying time. Immediately, 16 layers of Kaydry wipers or equivalent shall be placed on to the surface of the coating system and a 5-pound (2.25-kilogram) cylindrical weight with a diameter of 2.6 inches (66 millimeters) placed on the tissue. After 15 minutes, the weight shall be removed and the paper examined. Staining or discoloration on the paper caused by the coating indicates failure of this test. The appearance of these panels shall be evaluated as specified in 4.5.11 and shall be in accordance with the requirements of 3.19.

4.5.17 Pot life (types I-X). Separate samples of each individual coating of the non-skid coating system sufficient to fill a standard 1 quart (1 liter) can to within ½ inch (13 millimeters) of the top shall be conditioned and mixed in accordance with the manufacturer's ASTM F718 directions at 50, 75 and 90 °F (10, 24, and 32 °C) respectively, except for Type VIII, which shall be conditioned and mixed at 35 °F (2 °C). If an induction time is called for in the directions, the mixed components shall be kept at the mixing temperature during the induction time. The pot life shall be measured from the end of the induction time, if any, and the mixed coating shall be held at the temperature specified for the pot life. Minimum pot life for each type shall be in accordance with the requirements of 3.20. None of the mixed coating shall be removed for other tests during the determination of the pot life. At the end of the specified pot life, the coating shall meet all the requirements of 3.20. For conformance inspection only, compliance shall be determined by evaluating application properties (see 4.5.12) when applied to primed 6- by 6- by ¼-inch (150- by 150- by 3-millimeter) (nominal) steel plates, and following up with impact testing (see 4.5.3) at 4 days cure.

4.5.18 Fire resistance. The coating system shall be evaluated in accordance with the procedure specified in MIL-STD-1623. The average of three panels shall be used to determine conformance with the requirements of 3.21.

4.5.19 Flexibility (type III and X). The Type III or X coating shall be mixed, applied, and cured to the test panel in accordance with the manufacturer's ASTM F718 data sheet for the complete system. The Type III or X coating system test panel shall be tested over a 5-inch (127-millimeter) mandrel in accordance with ASTM F137 except bending shall be at 20 degrees at uniform rate. The panel shall be examined for cracking, breaking, or loss of adhesion immediately after bending. The panels shall be prepared and tested in such a manner that the ridges in the profile run parallel to the axis of the bend. Flexibility shall be in accordance with the requirements of 3.22.

4.5.20 Adhesion of the intermediate coat (type III only). The adhesion of the intermediate coat shall be determined in accordance with ASTM D4541 for the primer and intermediate coat of the non-skid coating system. Adhesion of the intermediate coat shall be in accordance with 3.23.

4.5.21 Immersion resistance (type X only). Four steel panels 12 by 6 by ⅛ inches (300 by 150 by 3 millimeters) (nominal) shall be prepared as specified in 4.4.3. The edges and backside of the panels shall be primed and coated with an anti-corrosive coating system such as MIL-PRF-23236, Grade A. Two of the sample panels shall have a 4- by ⅛-inch (100- by 3-millimeter) scribe, on a 45-degree angle centered in the bottom half of the panel, cut through the non-skid surface to bare metal. The panels shall then be completely immersed in either natural, or ASTM D1141 synthetic, seawater for a period of 12 hours after which they shall be removed to dry conditions for a period of 12 hours. This cycle shall be repeated for a period of 1 year, during which time the samples shall be inspected at least monthly for failures as noted in 3.24. At the end of the one-year test period the sample plates shall be removed, cleaned of any stains, and evaluated to the requirements of 3.24. The edges of the scribe shall be probed with a knife to determine the distance of corrosion undercutting, if any. Failure to meet all requirements of 3.24 shall constitute a failure of this test.

4.5.22 Cathodic protection (CP) compatibility (type X only). Two steel panels 12 by 6 by ⅛ inches (300 by 150 by 3 millimeters) (nominal) shall be prepared as specified in 4.4.3. The edges and backside of the panels shall be primed and coated with an anti-corrosive coating system such as MIL-PRF-23236, Grade C. Each panel shall be electrically connected to a commercial magnesium anode conforming to ASTM G8 and shall have a ¼-inch (nominal) hole drilled through the coating to the metal at the center of the test panel. The electrical resistance between a point on the surface of the anode and the metal in the drilled hole of the test panel shall be less than 0.01 ohm, when checked with an ohm meter. Connecting points on the test panel shall be coated with an epoxy compound for insulation. The test panel shall be installed in a modified ASTM G8 test in such a manner as to separate the test panel from the magnesium anode by two feet (nominal) for a period of 3 months. At the completion of the 3-month test, inspect each test panel for peeling, flaking, blistering, dissolving, or other failure. Lifting, peeling or undercutting around the drilled hole shall be measured. Test results shall be in accordance with the requirements of 3.25.

4.5.23 Pressure cycling (type X only). Three panels prepared as specified in 4.4.2.3 shall be coated with non-skid. The panels shall be placed into a pressure tank filled with fresh water and cycled from 0 to 600 psi (0 to 41.4 bars) for 2200 cycles. The pressure shall be held for one minute when pressure reaches less than 50 psi and when pressure is at maximum, 600 psi (41.4 bars). At 1100 cycles and at completion of the test, the panel shall be removed and inspected in accordance with the requirements in 3.26.

4.5.24 Strippability (type X only). Upon completion of pressure cycling testing, panels shall be used for strippability testing. Non-skid shall be buffed from the SHT substrate utilizing a 24 to 36 grit disc sander. The rate for stripping one SHT tile shall be measured in minutes. Results shall be in accordance with 3.27.

4.5.25 Storage stability (types I-X).

4.5.25.1 Long-term storage stability. Full, unopened containers constituting the components of the paint or kit [size of the container shall reflect the contract requirement (see 6.2)] of the coating system shall be kept undisturbed for 1 year at ambient laboratory conditions. Long-term storage stability shall be evaluated by running all the conformance inspection tests (see 4.3). Coating shall be in accordance with the requirements of 3.28.1.

4.5.25.2 Accelerated storage stability. Full, unopened container(s) constituting the components of the paint or kit (size of the container shall reflect the contract requirement [see 6.2]) of the coating system shall be kept undisturbed for a period of 4 weeks at a temperature of 120 °F (49 °C). Accelerated storage stability shall be evaluated by running all of the conformance inspection tests (see 4.3) after equilibrating the coating system at standard conditions. Coating shall be in accordance with the requirements of 3.28.2.

4.5.26 Weight. Three panels, each 6 by 12 by 1/8 inches (150 by 300 by 3 millimeters), shall be prepared as specified in 4.4.2.1. The tare weight of each panel shall be determined to the nearest 0.0002 pound (0.1 g). The areas of the test plates shall be determined to the nearest 0.02 in² (0.1 cm²). The non-skid coating system shall be applied to each panel in accordance with 4.4.3 so as to completely cover the steel plates, and the coating system shall be allowed to cure for 96 hours. After curing, any excess coating shall be cleaned from the edge of the panels. The weight of each panel shall be determined to the nearest 0.0002 pound (0.1 g), and the tare weight shall be subtracted to give the net weight of the coating. Average the areas of the three test plates. The three net weights shall be averaged and divided by the average test plate area to convert to grams per square centimeter. The weight of the coating will meet the requirements of 3.29.

4.5.27 Thickness (type XI only). Thickness shall be determined by measuring the steel plates prepared as specified in 4.4.2.1, with and without the deck covering, at 16 equally distributed points on the specimen by means of a dial thickness gauge and a template. The difference in thickness of the mounted steel plate and the coated steel plate shall be averaged to determine the thickness of the material. The thickness of the coating will meet the requirements of 3.30.

4.5.28 Size (type XI only). Each of the sample treads or rolls selected shall be visually and dimensionally examined to determine conformance to the requirements specified in 3.31.

4.5.29 Temperature resistance (type IX). Two panels, each 6 by 12 by 1/4 inches (150 by 300 by 6 millimeters), shall be prepared as specified in 4.4.3. The panels shall then be tested in accordance with ASTM D2485, test method B, for the time and temperatures specified. Samples shall be evaluated in accordance with the requirements of 3.32.

4.6 Toxicity. The contractor shall have the formulations and associated toxicological information available for review by the Navy Environmental Health Center (NEHC) as directed by the qualifying activity. The toxicity requirements shall conform to 3.2.5.

4.7 VOC limits. The VOC of each individual coat of the non-skid coating system, with all components mixed and in ready-to-use condition, shall be determined by Method 24 of the U.S. Environmental Protection Agency, 40 CFR60, Appendix A, Determination of Volatile Matter Content, Density, Volume Solids and Weight Solids of Surface Coatings. VOC shall be in accordance with the requirements of 3.2.2.

4.8 HAP content of coatings. Hazardous solvent content of each individual coating shall be determined in accordance with ASTM D3272 and ASTM E260. Solvent fractions shall be identified in accordance with ASTM E1252 with the results recorded as percent weight of the total paint. Alternate methods of analysis must be reviewed by NAVSEA. Formulation data may be used by manufacturers in lieu of testing to demonstrate compliance with hazardous air pollutant requirements of this specification. The manufacturer's formulation data must have a consistent and quantitatively known relationship to the testing required. Calculation of individual HAP contents can be based on either manufacturer evaluation of batches or supplier data for raw materials used in the product. HAP content shall be specified in 3.2.3.

4.9 Soluble and total metal content. Soluble and total metal content shall be determined on each individual coating of the dried powderized non-skid coating system in accordance with the California Administrative Code, Title 22, the waste extraction test or equivalent test procedure. The soluble metal content and the total metal content shall not exceed values which would cause the material to be classified as a hazardous waste (see tables II and III). The soluble and total metal content of each individual mixed and cured coating of the non-skid coating system shall be in accordance with the requirements of 3.2.4.1.

TABLE XVI. Suggested test methods for evaluating solid waste, physical/chemical methods, EPA SW-846.

Metal/material	Digestion test method
All metals, except chromium (VI)	3050
Chromium (VI)	3060
Antimony	7040 or 7041
Arsenic	7060 or 7061
Barium	7080 or 7081
Cadmium	7131
Total chromium	7190
Chromium (VI)	7195, 7196 or 7197
Lead	7421
Mercury	7470 or 7471
Nickel	7520 or 7521
Selenium	7740 or 7741
Silver	7760 or 7761

TABLE XVII. Suggested methods for chemical analysis of water and waste, EPA 600/4-79/020, USEPA, 1979.

Metal/material	Test method
Beryllium	210.1 or 210.2
Cobalt	219.1 or 219.2
Copper	220.1 or 220.2
Fluoride	340.1, 340.2 or 340.3
Molybdenum	246.1 or 246.2
Thallium	279.1 or 279.2
Vanadium	286.1 or 286.2
Zinc	289.1 or 289.2

4.9.1 Tantalum and tungsten content. The tantalum and tungsten content of the cured film shall be determined using any appropriate spectroscopy test method. Conduct the tests in accordance with the instrument manufacturer's directions for the use of the instrument. The manufacturer shall note test methodology, method rationale, and analytical accuracy. The test results for tantalum or tungsten shall be in conformance with the requirements of 3.2.4.1.

4.10 Performance in-service. A service test of Types I, II, V, VI, VII, VIII, and IX shall be conducted on a carrier flight deck in the landing area for composition L. Types I, V, VI, VII, VIII and IX, composition G shall be conducted on a carrier in a non-landing area. The coating system shall be mixed and applied according to the instructions furnished by the manufacturer (see 3.33). Type VI shall be cured for service within 3 days of application. Type VII must be cured for service within 24 hours of application. The coating system shall be examined after the test interval specified in table IX for the appropriate type and evaluated for conformance to 3.34. Type II, composition G and Types III and IV non-skid systems shall be tested on a smaller ship as designated by NAVSEA. Type X shall be tested on a submersible platform or vessel as designated by NAVSEA.

5. PACKAGING

5.1 Packaging. For acquisition purposes, the packaging requirements shall be as specified in the contract or order (see 6.2). When packaging of materiel is to be performed by DoD or in-house contractor personnel, these personnel need to contact the responsible packaging activity to ascertain packaging requirements. Packaging requirements are maintained by the Inventory Control Point's packaging activities within the Military Service or Defense Agency, or within the military service's system commands. Packaging data retrieval is available from the managing Military Department's or Defense Agency's automated packaging files, CD-ROM products, or by contacting the responsible packaging activity.

6. NOTES

(This section contains information of a general or explanatory nature that may be helpful, but is not mandatory.)

6.1 Intended use. The coatings covered by this specification are intended for use on general (walking) deck areas (Types I, II, III, IV, V, VI, VII, VIII, IX, X composition G, and XI), the flight and hangar decks of aircraft carriers (Types I, II, V, VI, VII, VIII, and IX compositions G and L) and on the landing decks of air-capable amphibious aviation and aviation ships (Types I, II, III, V, VI, VII, VIII, and IX composition G). Type I provides longer durability than Type II, however the factor of increased weight should be considered when using this system. Type V provides longer durability than Type I, but attention is given to the significantly shorter pot life. Type VI is a fast curing non-skid material for use when application windows are limited. Type VII is a temporary repair non-skid that is ready for service in 24 hours, however, it may have a relatively short service life making it unsuitable for normal non-skid installations. Type VIII is intended for application at low temperatures, but it should not be considered a fast cure product for application at normal or elevated conditions. Type III non-skid systems are intended for use where flexibility or thick smoothing capability is needed to correct drainage. Type III is not intended to be used on aircraft carriers if the underlayment is used due to compressibility of the materials under heavy aircraft. Type IV can be used on walking surfaces, but is not intended for aircraft landing decks. Type XI non-skid system is approved for use in well deck catwalk areas, airlocks, boatswain storerooms, elevator machinery rooms, boat gear repair station, chain locker sump, damage control maintenance shop, deck gear locker, drying rooms, machinery repair shops, mooring stations, nixie winch room, officer of the deck stations, replenishment-at-sea stations, rolling airframe missile handling equipment rooms, sideport door machinery spaces, signal shelter, stern gate machinery and operating gear rooms, and valve repair and test shops. Although laboratory testing is done between 35 °F (2 °C) and 90 °F (32 °C), each individual coating of these non-skid systems is applied in the fleet between 40 °F (4 °C) and 120 °F (49 °C).

6.2 Acquisition requirements. Acquisition documents should specify the following:

- a. Title, number, and date of the specification.
- b. Type and composition required (see 1.2). For Type XI specify size of treads or width of rolls.
- c. Specific issue of individual documents referenced (see 2.2.1 through 2.3).
- d. Color required (see 3.16).
- e. Toxicity requirements (see 3.2.5 and 6.5)
- f. Packaging and label requirements (see 5.1 and 6.6). (Attention is directed to regulatory and safety requirements for labels.)
- g. Data sheets required (see 6.5).

6.3 Qualification. With respect to products requiring qualification, awards will be made only for products which are, at the time of award of contract, qualified for inclusion in Qualified Products List QPL No. 24667 whether or not such products have actually been so listed by that date. The attention of the contractors is called to these requirements, and manufacturers are urged to arrange to have the products that they propose to offer to the Federal Government tested for qualification in order that they may be eligible to be awarded contracts or orders for the products covered by this specification. Information pertaining to qualification of products may be obtained from Naval Sea Systems Command, ATTN: SEA 05M2, 1333 Isaac Hull Avenue, SE, Stop 5160, Washington Navy Yard DC 20376-5160 or CommandStandards@navy.mil.

6.4 Shelf-life. This specification covers items where shelf-life is a consideration. Specific shelf-life requirements should be specified in the contract or purchase order. The shelf-life codes are contained in the Federal Logistics Information System Total Item Record. Additive information for shelf-life management may be obtained from DoD 4140.27-M; Shelf-Life Management Manual, or the designated shelf-life Points of Contact (POC). The POC should be contacted in the following order: (1) the Inventory Control Points (ICPs), and (2) the DoD Service and Agency administrators for the DoD Shelf-Life Program. Appropriate POCs for the DoD Shelf-Life Program can be contacted through the DoD Shelf-Life Management website: <http://www.shelflife.hq.dla.mil/>.

6.5 Material safety data sheets. The contracting activity should be given material safety data sheets (MSDS) at the time of contract award. The MSDS should be provided in accordance with FED-STD-313 and ANSI Z400.1. Contracting officers should identify those activities requiring copies of completed Material Safety Data Sheets (MSDS) prepared as specified in FED-STD-313. Additional required government information is contained in FED-STD-313. In order to obtain the MSDS, federal acquisition regulation (FAR) clause 52.223-3 must be in the contract.

6.6 Packaging recommendations. Suggested packaging requirements are contained on tables XVIII and XIX.

TABLE XVIII. Packaging.

Packaging	Recommended requirements for direct Government acquisitions
Containers	<p>(1) Cans should be in accordance with Type V, Class 2, of PPP-C-96. An interior coating should be required for cans containing water-based coatings. Plan B coating and side seam stripping should be required. Wire handles treated to resist corrosion should be required for 1 gal (4 L) cans. Can closure should be in accordance with the appendix to PPP-C-96.</p> <p>(2) 1 and 5 gal (4 and 19 L) pails should be in accordance with Type II, Class 3 of PPP-P-704. An interior coating should be required for cans containing water-based coatings. All containers should have an exterior coating. Wire handles treated to resist corrosion should be required. Exterior plan B coating and side seam stripping required for Type XI sealing compound.</p> <p>(3) The 6 or 6½ gal (23 or 24.5 L) double-compartmented pail should be in accordance with Type II, Class 5 or 11 of PPP-P-704. An interior coating should be required for pails containing water-based coatings. All pails should have an exterior coating. Wire handles or bails treated to resist corrosion should be required. The second compartment may be formed using a metal or plastic insert having a tray or saddle shape that is designed to rest over the edge of the pail. The insert should fit tightly, and should be of sufficient size to accommodate the unit pack curing agent, component B. The pail, lid, and insert should fit tightly without leaking. Gaskets may be used if necessary to ensure a leakproof fit.</p> <p>(4) Five-ounce collapsible tubes should conform to Group B class at contractor option, in accordance with PPP-C-186 with each tube placed in folding or set-up paperboard box. Intermediate pack quantities and box closure should be as specified in the appendix to the applicable box specification. The intermediate domestic corrugated fiberboard box should be constructed of fire-retardant fiberboard.</p> <p>(5) Type XI non-skid of like kind and size, and in quantities specified (see 6.2) should be packaged in fiberboard boxes in accordance with ASTM D5118 and ASTM D1974.</p> <p>(6) All containers should comply with the requirements of the Uniform Freight Classifications (UFC), the National Motor Freight Classification (NMFC), and the applicable requirements of the Code of Federal Regulations 49CFR, Department of Transportation (DOT).</p> <p>(7) Unit of procurement: The coatings covered by this specification should be purchased by volume. The unit of procurement should be in multiples of 1 L or 1 U.S. liquid gallon at 60 °F (15.5 °C). Type XI sealing compound should be procured in 5-ounce metal collapsible tubes, 1-gallon cans, or 5-gallon pails.</p>
Commercial packaging	<p>(1) Commercial packaging should be to ASTM D3951.</p> <p>(2) All containers should comply with the requirements of the Uniform Freight Classifications (UFC), the National Motor Freight Classification (NMFC), and the applicable requirements of the Code of Federal Regulations 49CFR, Department of Transportation (DOT).</p>

TABLE XVIII. Packaging - Continued.

Packaging	Recommended requirements for direct Government acquisitions
Packing	Packing should be specified as follows: <ol style="list-style-type: none"> (1) Overseas delivery packing. Intermediate containers of like size kits of paint should be packed in close-fitting wood boxes conforming to ASTM D6251 overseas type, or ASTM D6880. Box closure and strapping should be as specified in the applicable box specification or the appendix thereto except that strapping should be flat and the finish B. (2) Domestic delivery (Level B) packing. Level B packing should be as for level A, except that boxes should be domestic type or class and the strapping should be finish A or B. Type XI cans will not require the exterior plan B coating. (3) Commercial packing. The paint, in the unit kit and intermediate containers should, as applicable, be packed in multiples of like sizes in accordance with UFC, NMFC and 49CFR requirements. (4) Type XI sealing compound. Sealing compound should be packed in containers for the level of packing specified (see 5.1) in accordance with PPP-C-186, PPP-C-96, PPP-P-704, and the applicable appendix thereto.
Palletization	Guidance concerning government rules for the palletization of intermediate containers is contained in MIL-HDBK-774. Only one size unit or intermediate container should be placed on a pallet.
Intermediate containers	Coatings should be packaged in intermediate containers as kits. Intermediate containers should be close-fitting corrugated fiberboard boxes in accordance with UFC, NMFC, and 49CFR requirements. Fiberboard used in the construction of interior (unit and intermediate) and exterior containers, including interior packaging forms, should conform to the ASTM D4727. ASTM D4727 classes should be domestic fire-retardant or weather resistant fire-retardant (see 6.2).
Packing for acquisitions involving direct delivery to Navy ships or installations	Treated lumber and plywood. All lumber and plywood, including laminated veneer materials, used in shipping container and pallet construction, member, blocking, bracing, and reinforcing must be fire-retardant treated material in accordance with MIL-L-19140 as follows: <ol style="list-style-type: none"> (1) General use, weather resistant: MIL-L-19140, Type II, Category I. (2) General use, non-weather resistant: MIL-L-19140, Type I, Category I.
Unit kits	The coatings covered by this specification should be packed and packaged as kits. Material safety data sheets (MSDS) and product/procedure data sheets and a copy of the MSDS and company product data/procedure sheets should be attached to the shipping document for each destination (see 6.4).
VOC Certification sheets	VOC Certification sheets will be provided by the manufacturer for each batch of combined Parts A & B for each coat of the coating system when requested by the procuring activity.

TABLE XIX. Marking.

Marking type	Recommended Marking
Interior packs, containers and palletized loads	Should be in accordance with MIL-STD-2073-1.
Bar codes	Marking should include bar codes.
Hazardous warnings	<p>(1) Labels should be in accordance with 29 CFR1910, 1915, 1917, 1918, 1926, and 1928, as well as PPP-P-1892.</p> <p>(2) All individual containers should have the following marking: “CAUTION: This paint contains volatile solvents, with probable hazardous vapors. Use with adequate ventilation. Avoid prolonged breathing of vapors or spray mists. The solvents are highly flammable, avoid open flame and smoking.”</p> <p>(3) Each component container, shipping container, and palletized load should be marked with the appropriate hazardous symbol.</p> <p>(4) Unit containers should be marked:</p> <p>(a) “This product is Asbestos, Lead, Chromium, Cadmium and Silica free, except for possible trace levels.”</p> <p>(b) “This product is free of volatile organic hazardous air pollutants (VOHAPS/HAPS), except for possible trace levels.”</p>
Volatile organic content (VOC)	“Contains (insert VOC content) grams per liter (insert VOC content in lb/gal) of volatile organic content per 40 CFR60, Appendix A (EPA) Method 24. Maximum thinning allowed is (insert number in g/L, lb/gal and volume/gal [if appropriate].”
Hazardous air pollutants	“Contains [insert HAP content here in g/L and lb/gal] solids (nonvolatiles) per 40 CFR63.”
Shelf-life	Each unit container, intermediate container where applicable, and shipping container should be marked as follows: “This coating has a 1-year nonextendable shelf-life and shall not be used after (insert the month and year which are one year later than the date of manufacture).”

6.7 Supersession data. This specification supersedes MIL-PRF-24667B(SH) dated 03 June 2005, and MIL-PRF-17951E(SH) Amendment 2, dated 17 September 1992, in their entirety.

6.8 Subject term (key word) listing.

Adhesive

Aluminum oxide

Color topping

Nonslip

Paint

Shear strength

Silicon carbide

Strip strength

Topcoat

Viscosity

6.9 Changes from previous issue. Marginal notations are not used in this revision to identify changes with respect to the previous issue due to the extent of the changes.

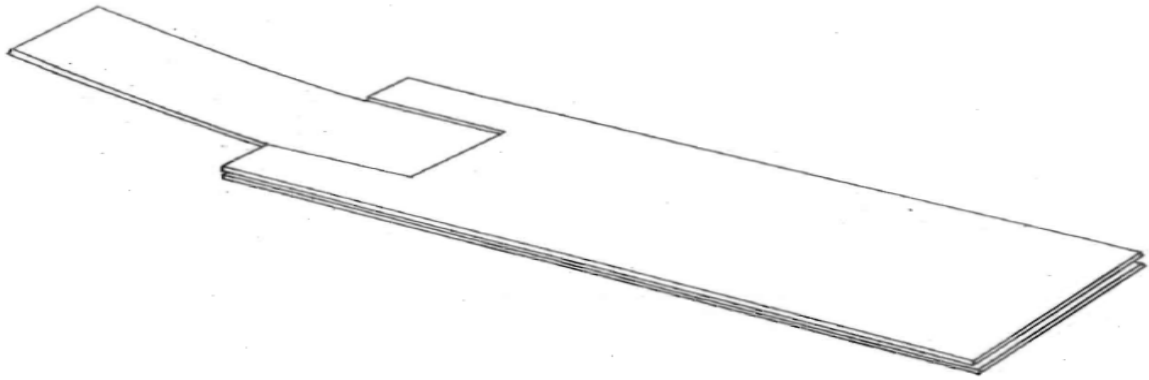

FIGURE 3. Template.

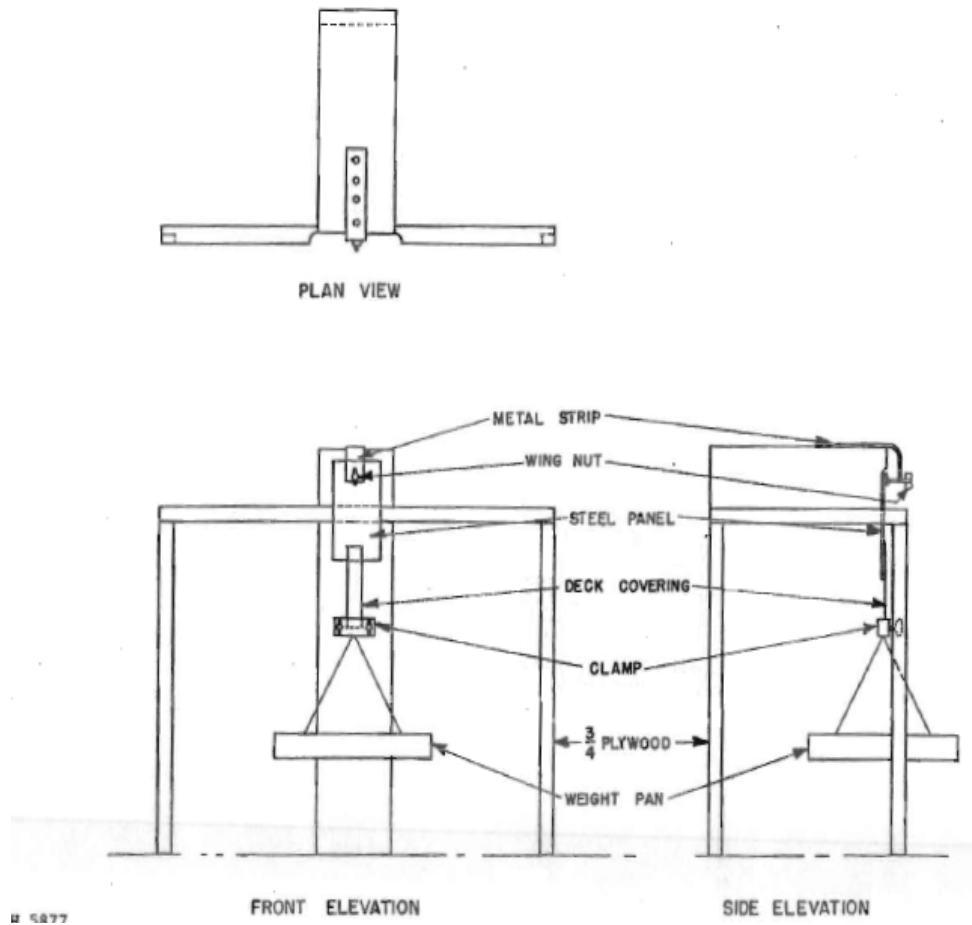

FIGURE 4. Adhesion testing machine.

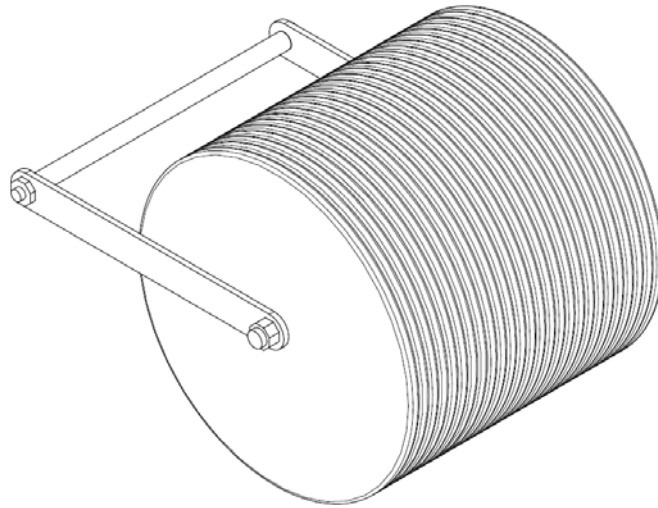

FIGURE 5. Multidisk roller for preparation of strip adhesion strength specimens, assembled view.

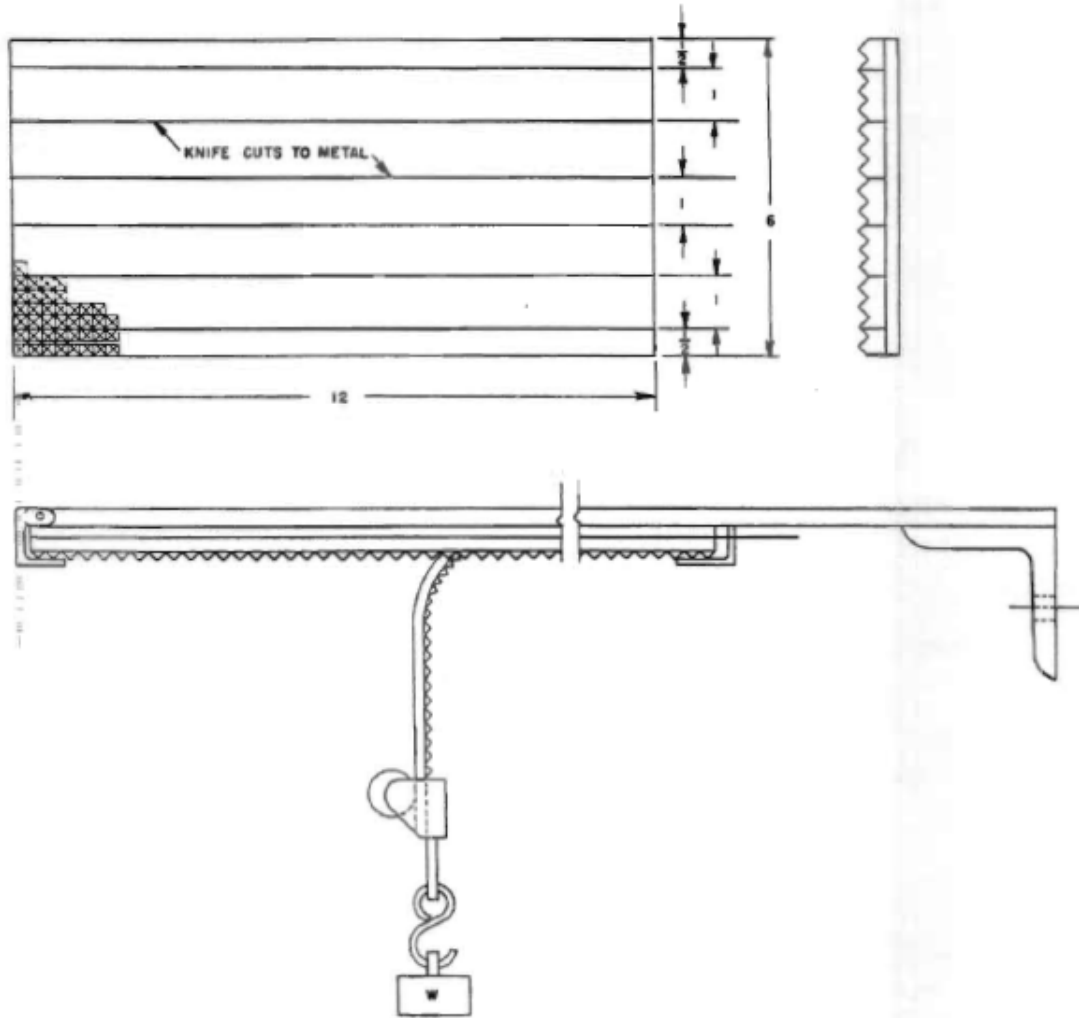

FIGURE 6. Strip adhesion test.

Custodian:
Navy – SH

Preparing Activity:
Navy – SH
(Project 8010-2006-029)

Review Activity:
AF – 99

NOTE: The activities listed above were interested in this document as of the date of this document. Since organizations and responsibilities can change, you should verify the currency of the information above using the ASSIST Online database at <http://assist.daps.dla.mil>.